





CONTENTS

SECTION 1 Whipstock System

Whipstock System with Mechanical Anchor PL-WSMSAT	3
Whipstock System with Hydraulic Anchor PL-WSHSA.....	4
Whipstock System Open Hole PL-WSMOH	5

SECTION 2 Technological equipment for sectional and stepped well casing

Technological equipment for sectional well casing PL-CB/CT	8
Hydraulic stage cementing tool PL-HST	9
Cementing sleeve PL-MCT	10

SECTION 3 Liner Hanger

Liner Hanger with Packer and Inner String (PL-LH/PISHSG /PBR)	14
Liner Hanger with Packer and Polished Bore Receptacle (PL-LH/PHRDG/PBR)	15
Hydraulic string liner hanger PL-LH/PHDG	16
Hydraulic packer string liner hanger PL-LH/PHSG	17
Hydraulic double-gripping packer liner hanger PL-LH/HDG	18
Liner hanger hydraulic double-grip packer double-row casing PL-LH/HD2G	19
Liner hanger packer mechanical PL-LH/PMSG	20
Liner hanger mechanical PL-LH/MSG	21

SECTION 4 Casing disconnect tool

Hydraulic disconnecter PL-HRT.....	24
Hydraulic disconnecter PL-HRTRH.....	25
The disconnecter hydraulic - mechanical PL-H/MRT.....	26
Hydraulic disconnecter PL-HRTM.....	27
The mechanical disconnecter PL-MRT.....	28

SECTION 5 External casing packer

Hydraulic casing packer PL-PHME	32
Packer Hydraulic External PL-PME.....	33
Packer hydraulic PL-PH.....	34

SECTION 6 Downhole equipment

Packer PL1- X	38
Packer PL-C	39
Model "PT-2" On-Off Tool	40
The Latch Seal the permanent packer (Permapack)	41
Sliding Sleeve PL-XA (SSD)	42
Hydraulic Circulation Valve PL-CVH	43
Depression differential sub PL-DS	44
Landing nipples PLX and PL-XN	45
SAFETY SUB (shear type) PL-SS	46
Pump-out Plug PL-POP	47
Casing Scraper (mechanical) PL-CS	48
Casing Drift PL-CD	49
Depth Ejector Jet Pump PL-DEP	50
Support-unloading device PL-SUD / Crossover PL-C.....	51

SECTION 7 Auxiliary equipment

Stinger PL-St	54
Cementing head PL-CH	55
Cementing head PL-CHB	56
Floats	57
Centralizers	58
Junk sub	59
Filters	60



Whipstock System with Mechanical Anchor PL-WSMSA

Mechanical Anchor Whipstock System whipstock ensures precise deviation of the milling bottomhole assembly from the original wellbore axis during casing window milling. The mechanical anchor allows its deployment in casing strings with various wall thicknesses, enhancing the tool's versatility. The system ensures accurate orientation and adaptability even in challenging milling environments.

THE EQUIPMENT IS USED FOR:

- creating a milling window in casing strings or open hole sections;
- deflecting the drill string in a predetermined direction;
- ensuring a controlled kickoff of a new wellbore;
- executing lateral sidetrack initiation;
- bypassing damaged or problematic intervals to eliminate stuck.

EQUIPMENT SET INCLUDES:

- whipstock with mechanical anchor
- window Mill
- watermelon Mill (Bottom)
- watermelon Mill (Top) (wedge inclination angle 2°)

DESIGN ADVANTAGES:

- independent from hydraulic pressure activation;
- simple and robust design;
- quick and efficient setting procedure;
- increased reliability in wells with challenging downhole conditions.

OPERATION:

- The tool is run into the well as part of the bottom-hole assembly (BHA).
- At the target depth, axial set-down weight is applied.
- The axial load activates the mechanical setting mechanism, initiating anchor deployment without the use of hydraulic pressure.
- Anchor slips expand and securely lock the anchor unit inside the casing string or open hole section.
- Once fixation is confirmed, the whipstock remains precisely oriented for subsequent operations.
- Window milling is then performed, after which the drilling assembly slides along the inclined wedge surface, providing controlled wellbore deviation and sidetrack initiation.

Casing Size OD (in/mm)	Wedge Section OD (in/mm)	Anchor Section OD (in/mm)	Window Mill OD (in/mm)	Watermelon Mill OD (in/mm)
5 1/2" 139,7	4 1/3" 110	4 1/3" 110	4 1/4" - 4 7/8" 108-123,8	4 1/4" - 4 7/8" 108-123,8
5 3/4" 146,05	4 2/3" 118,3	4 2/3" 118,3	4 2/3" - 4 7/8" 118,3-123,8	4 2/3" - 4 7/8" 118,3-123,8
6 5/8" 168,5	5 5/16" 135	5 5/16" 135	5 1/2" - 5 3/4" 139,7-146,05	5 1/2" - 5 3/4" 139,7-146,05
7" 177,8	5 5/16" 135	5 5/16" 135	5 3/4" - 6 1/8" 146,05-156	5 3/4" - 6 1/8" 146,05-156
9 5/8" 244,5	7 7/8" 200	7 7/8" 200	7 1/2" - 8 1/2" 190-215,9	7 1/2" - 8 1/2" 190-215,9



Whipstock System with Hydraulic Anchor PL-WSHSA

Whipstock with a hydraulic anchor is a system designed for efficient and reliable window milling and sidetracking operations. The hydraulic anchor is set by applying internal pressure, which activates and locks the mechanism inside the casing or formation. The hydraulic anchor ensures proper orientation and allows window milling to be performed in a single run. As a result, rig time is reduced, non-productive time is minimized, and significant cost savings are achieved through lower operational expenses.

THE EQUIPMENT IS USED FOR:

- creating a milling window in casing strings or open hole sections;
- deflecting the drill string in a predetermined direction;
- ensuring a controlled kickoff of a new wellbore;
- executing lateral sidetrack initiation;
- bypassing damaged or problematic intervals to eliminate stuck.

EQUIPMENT SET INCLUDES:

- whipstock with hydraulic anchor
- window Mill
- watermelon Mill (Bottom)
- watermelon Mill (Top) (wedge inclination angle 2°)

DESIGN ADVANTAGES:

- reliable fixation due to hydraulic activation;
- no requirement for mechanical weight setting on bottom;
- suitable for vertical, deviated, and horizontal wells;
- controlled activation at a predetermined pressure;
- reduced risk of whipstock rotation or displacement during milling operations.

OPERATION:

- The tool is run into the well as part of the drill string assembly.
- At the target depth interval, drilling fluid pressure is applied.
- Hydraulic pressure activates the piston mechanism.
- Anchor slips expand and securely lock the anchor unit inside the casing.
- Once fixation is confirmed, window milling operations are performed.
- The drilling assembly slides along the inclined wedge surface, providing controlled wellbore deviation and sidetrack initiation.

Casing Size OD (in/mm)	Wedge Section OD (in/mm)	Anchor Section OD (in/mm)	Window Mill OD (in/mm)	Watermelon Mill OD (in/mm)
5 1/2" 139,7	4 1/3" 110	4 1/3" 110	4 1/4" - 4 7/8" 108-123,8	4 1/4" - 4 7/8" 108-123,8
5 3/4" 146,05	4 2/3" 118,3	4 2/3" 118,3	4 2/3" - 4 7/8" 118,3-123,8	4 2/3" - 4 7/8" 118,3-123,8
6 5/8" 168,5	5 5/16" 135	5 5/16" 135	5 1/2" - 5 3/4" 139,7-146,05	5 1/2" - 5 3/4" 139,7-146,05
7" 177,8	5 5/16" 135	5 5/16" 135	5 3/4" - 6 1/8" 146,05-156	5 3/4" - 6 1/8" 146,05-156
9 5/8" 244,5	7 7/8" 200	7 7/8" 200	7 1/2" - 8 1/2" 190-215,9	7 1/2" - 8 1/2" 190-215,9



Whipstock System Open Hole PL-WSMOH

The Whipstock System Open Hole is a specialized downhole tool designed for sidetracking and lateral drilling operations in open-hole wellbores.

The system provides a reliable and cost-effective solution for:

- initiating a new lateral borehole from the main wellbore;
- establishing controlled directional drilling trajectories;
- bypassing obstructions or problematic well intervals;
- straightening a deviated or crooked well section;
- improving reservoir access through multi-lateral drilling.

The whipstock system is intended for installation in an open-hole section.

Anchoring is achieved through a mechanical slip system, followed by cementing to prevent rotation or displacement during milling and drilling operations.

Whipstock system can be installed 6" to 12 ¼".

EQUIPMENT SET INCLUDES:

- whipstock with mechanical anchor
- setting tool
- filter pipe
- drill pipe plug

DESIGN ADVANTAGES:

- ensures proper drilling fluid circulation during operations, maintaining wellbore stability and safe tool setting;
- the system can be oriented using MWD or GyroTracker systems for accurate azimuthal positioning;
- provides reliable fixation of the whipstock;
- ensures clear and secure execution of the release and separation from the whipstock after completion of operations.

OPERATION:

- Connect the drill string to the setting tool and run in the well whipstock system.
- When running the whipstock system orient the whipstock.
- When whipstock running to the head cement bridge measure the weight move up and down, restore circulation and flush the well AND orient the whipstock (if necessary).
- Stop circulating and unloading activate the anchor assembly and install it.
- Check the installation straining drill string tension 2 tones more than own weight.
- Load for disconnect drill string. Check disconnect to pool the string, but no more than 1-1,5 m to prevent the setting tool from being pulled out of the whipstock.
- Start perating for cementing. After pumping cement, drop the drill pipe plug and pump to whipstock. When the plug is seated in the whipstock, the pressure will increase, indicating that the cement is in the area of the whipstock system.
- The setting tool is lifted from the well.







Technological equipment
for **sectional** and **stepped**
well casing

Technological equipment for sectional well casing PL-CB/CT

is designed for running and casing of oil and gas wells in especially difficult geological conditions. It has the ability to run and fasten two or more sections of casing, and the connection of the sections is made in an open and cased wellbore.

The process of running casing sections and their fastening is performed: running the bottom casing section, its cementing, running the top casing section, connecting with the bottom one with tension by the calculated value, flushing the well, its subsequent cementing, closing the holes of the cementing sleeve. This scheme of sectional casing is a classic one and is the most common, both for technical and production casing.

DESIGN ADVANTAGES:

- running and cementing of deviated and horizontal wells;
- cementing of sections in strained state;
- availability of several schemes of flushing holes opening during cementing of the first section;
- design options allowing for rotation of the section during lowering;
- reliable packer sealing of the junction;
- availability of a check valve;
- protective casing for connection of sections;
- possibility of emergency disconnection of the upper section from the lower one by turning to the right;
- elements of technological equipment are destroyed by PDC type chisel;
- use under significant pressure and temperature fluctuations.



Casing, in / (mm)	Tooling sizes, in / (mm)		Maximum pressure, psi / (MPa)		Load capacity, t
	Outer diameter max.	Inner diameter min.	Cementing	Testing	
5 1/2" (139,7)	7,67" (195)	4,76" (121)	4350 (30)	14500 (100)	180
5 3/4" (146)	7,67" (195)	5" (127)	4350 (30)	14500 (100)	190
6 5/8" (168,3)	8,38" (213)	5,94" (151)	4350 (30)	14500 (100)	200
7" (178)	8,38" (213)	6,25" (159)	4350 (30)	14500 (100)	200
9 5/8" (244,5)	12" (305)	8,85" (225)	3625 (25)	13050 (90)	250
12 3/4" (323,9)	14,84" (377)	11,88" (302)	2900 (20)	7250 (50)	300
13 3/8" (339,7)	15,43" (392)	12,63" (321)	2900 (20)	6530 (45)	300

* design dimensions can be changed and manufactured to individual technological conditions of the customer's well

Hydraulic stage cementing tool PL-HST

designed for running the casing in one section, with subsequent cementing in two stages. PL-HST sleeves are used when cementing casing of considerable weight and length, as well as in non-isolated intake zones in order to reduce repression on productive formations, as well as for collar cementing.

THE EQUIPMENT SET INCLUDES:

- step cementing coupling;
- stop clutch;
- bottom separating plug;
- top separating plug.

DESIGN ADVANTAGES:

- running and cementing wells in difficult geological and technological conditions;
- availability of redundant option of flushing holes opening; locking of closing sleeve;
- adjustment of flushing orifices opening pressure;
- wide range of working pressure;
- anti-rotation performance of plugs and their fixation;
- elements of PL-HST couplings are destroyed by PDC type chisel;
- reliability and ease of use.

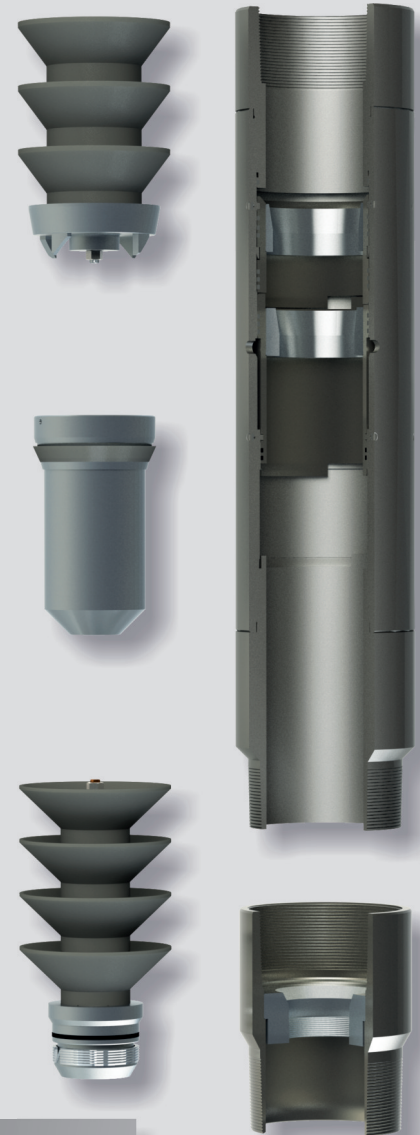

Casing, in /(mm)	Tooling sizes, in /(mm)		Maximum pressure, psi / (MPa)		Load capacity, t
	Outer diameter max.	Inner diameter min.	Activation	Testing	
5 " (127)	5,90" (150)	4,25" (108)	5800 (40)	14500 (100)	150
5 1/2" (139,7)	7,67" (195)	4,76" (121)	5800 (40)	14500 (100)	180
5 3/4" (146)	7,67" (195)	5" (127)	5800 (40)	14500 (100)	190
6 5/8" (168,3)	8,38" (213)	5,94" (151)	5800 (40)	14500 (100)	200
7" (178)	8,38" (213)	6,25" (159)	5800 (40)	14500 (100)	200
9 5/8" (244,5)	12" (305)	8,85" (225)	4350 (30)	13050 (90)	250
12 3/4" (323,9)	14,84" (377)	11,88" (302)	3625 (25)	7250 (50)	300
13 3/8" (339,7)	15,43" (392)	12,63" (321)	3625 (25)	6530 (45)	300

* design dimensions can be changed and manufactured to individual technological conditions of the customer's well

Cementing sleeve PL-MCT

is designed for running casing, "liners", in one section with their subsequent collar cementing, as well as for cementing casing of lower or upper section in two stages. More often used when running down and cementing "liners" with filtering part. PL-MCT cementing sleeves are used together with other process equipment based on technological conditions of the well.

THE EQUIPMENT SET INCLUDES:

- step cementing coupling;
- stop clutch;
- bottom separating plug;
- top separating plug.

DESIGN ADVANTAGES:

- running and cementing wells in difficult geological and technological conditions;
- availability of redundant option of flushing holes opening; locking of closing sleeve;
- adjustment of flushing orifices opening pressure;
- wide range of working pressure;
- anti-rotation performance of plugs and their fixation;
- elements of PL-MCT couplings are destroyed by PDC type chisel;
- reliability and ease of use.

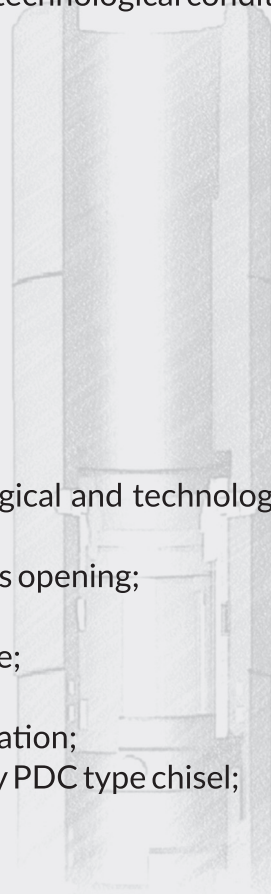

Casing, in / (mm)	Tooling sizes, in / (mm)		Maximum pressure, psi / (MPa)		Load capacity, t
	Outer diameter max.	Inner diameter min.	Activation	Testing	
4 1/2" (127)	5,90" (150)	3,85" (98)	4350 (30)	14500 (100)	150
5 " (127)	5,90" (150)	4,25" (108)	4350 (30)	14500 (100)	150
5 1/2" (139,7)	7,67" (195)	4,76" (121)	4350 (30)	14500 (100)	180
5 3/4" (146)	7,67" (195)	5" (127)	4350 (30)	14500 (100)	190
6 5/8" (168,3)	8,38" (213)	5,94" (151)	4350 (30)	14500 (100)	200
7" (178)	8,38" (213)	6,25" (159)	4350 (30)	14500 (100)	200
9 5/8" (244,5)	12" (305)	8,85" (225)	3625 (25)	13050 (90)	250

* design dimensions can be changed and manufactured to individual technological conditions of the customer's well

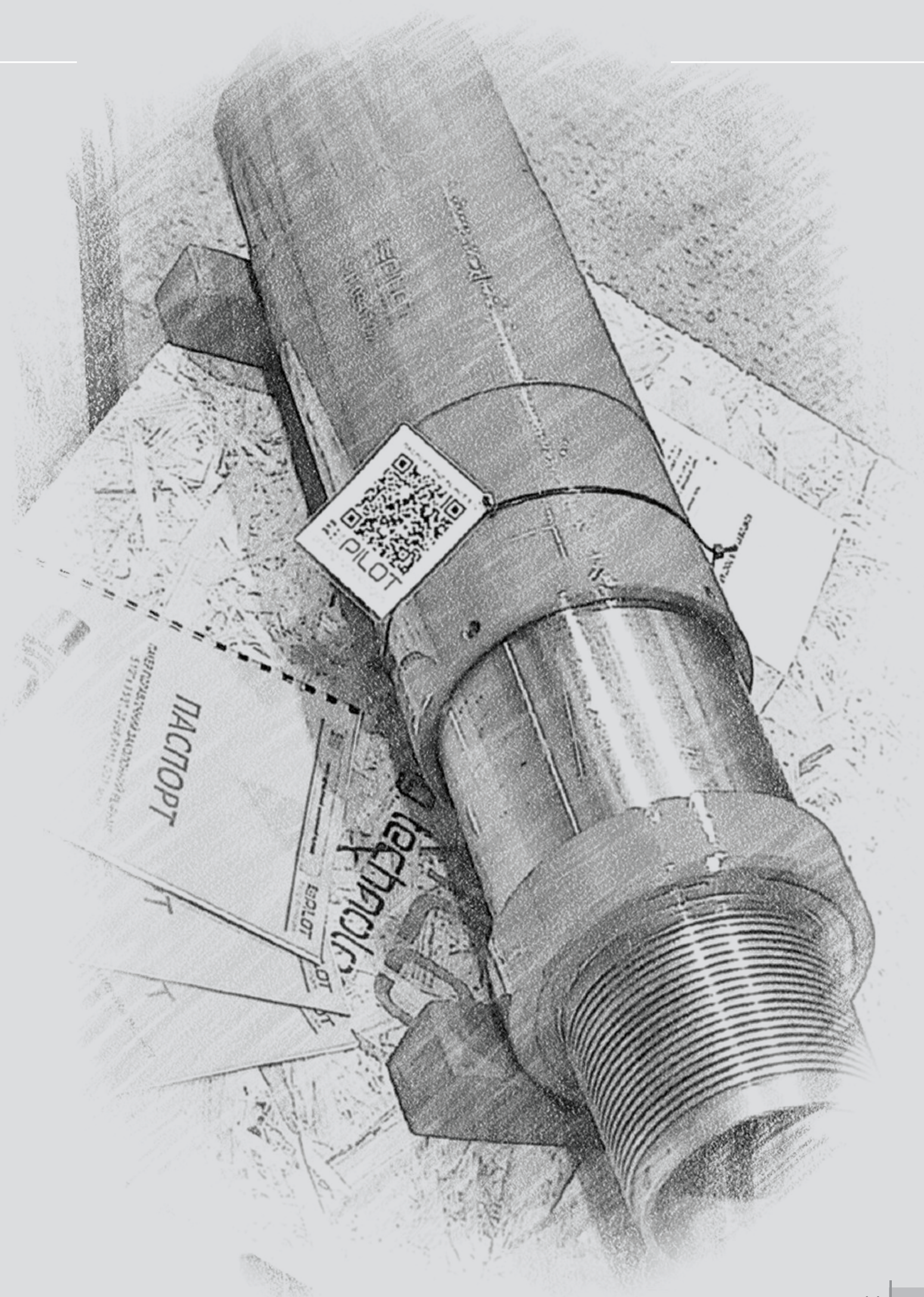

 **PILOT**
drilling technologies

← **FIXED**

 **PILO**
drilling technoc



PILOT
drilling technologies
S/N 02-10.21



TURNKEY

CT
ologies

Liner hanger

Liner Hanger with Packer and Inner String (PL-LH/PISHSG /PBR)

The Liner Hanger with Packer and Inner String is designed to provide precise and reliable positioning of the tailpipe within the casing without the need for cementing, ensuring effective wellbore preparation before subsequent operations. The system allows controlled circulation of wash fluid through the sealing coupler, into which the stinger is inserted, enabling efficient removal of cuttings from the wellbore.

The tool allows for control of wash fluid flow and minimizes pressure losses, while permitting the safe disconnection of the tailpipe after completion of washing operations. It can be reciprocated and rotated during running, ensuring uniform cleaning the wellbore. The liner hanger allows connection with a tie-back extension string and, if required, installation of a mechanical backup packer.

THE EQUIPMENT SET INCLUDES:

- hydraulic liner hanger
- mechanical liner packer
- hydraulic setting tool
- landing collar
- sealing coupler
- stinger
- dart plug

DESIGN ADVANTAGES:

- enables running and setting operations in complex geological and drilling conditions;
- wide operating pressure range;
- high reliability and ease of operation;
- effectively cleans the wellbore during the running liner filter.



Size (in./mm)		Weight (lb/ft, kg/m)		Maximum pressure, psi / (Mpa)		Load capacity, t
Liner	Casing	Liner	Casing	Activation	Test	
4 1/2" (114,3)	6 5/8" (168,3)	9,5 - 13,5 14,1 - 20,1	20,0 - 28,0 7,32 - 10,59	4350 (30)	14500 (100)	75
	7" (178)		26,0 - 38,0 38,7 - 56,5			
5" (127)	6 5/8" (168,3)	17 - 32,6 25,3 - 48,5	20,0 - 32,0 29,8 - 47,6	4350 (30)	14500 (100)	80
	7" (178)		26,0 - 38,0 38,7 - 56,5			
6 5/8" (168,3)	9 5/8" (244,5)	20,0 - 32,0 29,8 - 47,6	40,0 - 53,5 59,5 - 79,6	4350 (30)	14500 (100)	100
7" (178)	9 5/8" (244,5)	26,0 - 38,0 38,7 - 56,5	40,0 - 53,5 59,5 - 79,6	4350 (30)	14500 (100)	110

Liner Hanger with Packer and Polished Bore Receptacle (PL-LH/PHRDG/PBR)

The PL-LH/PHRDG/PBR is designed for suspending the liner casing string in the wellbore. During running in hole, the system allows reciprocation and rotation of the liner string. Before cementing, the hanger is hydraulically set and released from the running tool. After release, circulation is maintained, liner cementing is performed, and the liner top packer is set.

The liner hanger allows connection with a tie-back extension string and, if required, installation of a mechanical backup packer.

THE EQUIPMENT SET INCLUDES:

- hydraulic liner hanger
- mechanical liner top packer
- hydraulic disconnecter
- hydraulic setting tool
- landing collar
- set activate plugs and drop ball

DESIGN ADVANTAGES:

- enables running and setting operations in complex geological and drilling conditions;
- wide operating pressure range;
- high reliability and ease of operation;
- positive locking of anchoring slips.



Size (in./mm)		Weight (lb/ft, kg/m)		Maximum pressure, psi / (Mpa)		Load capacity, t
Liner	Casing	Liner	Casing	Activation	Test	
4 1/2" (114,3)	6 5/8" (168,3)	9,5 - 13,5 14,1 - 20,1	20,0 - 28,0 7,32 - 10,59	4350 (30)	14500 (100)	75
	7" (178)		26,0 - 38,0 38,7 - 56,5			
5" (127)	6 5/8" (168,3)	17 - 32,6 25,3 - 48,5	20,0 - 32,0 29,8 - 47,6	4350 (30)	14500 (100)	80
	7" (178)		26,0 - 38,0 38,7 - 56,5			
6 5/8" (168,3)	9 5/8" (244,5)	20,0 - 32,0 29,8 - 47,6	40,0 - 53,5 59,5 - 79,6	4350 (30)	14500 (100)	100
7" (178)	9 5/8" (244,5)	26,0 - 38,0 38,7 - 56,5	40,0 - 53,5 59,5 - 79,6	4350 (30)	14500 (100)	110

Hydraulic string liner hanger PL-LH/PHDG

is designed to suspend a section of "liner" casing in pre-lowered casing after cementing or without cementing the well. While anchoring casing provides its straightness during cement slurry setting thus preventing unloading on cement slurry, effectively acting on contact between cement slurry and casing string. PL-LH/PHDG liners hanger is used for both vertical and directional wells and may be combined with various process equipment.

A stop collar, plug or ball for it is delivered together with the suspension, depending on the technological features of the well.

DESIGN ADVANTAGES:

- lowering and securing wells in difficult geological conditions;
- wide working pressure range;
- reliability and ease of use;
- reliable fixation of rams from axial movement.



Casing, in / (mm)	Installation range in / (mm)	Inner diameter max.in / (mm)	Maximum pressure, psi / (MPa)		Load capacity, t
			Activation	Testing	
3 1/2" (88,9)	4,6"-5,12" (117-130)	2,95" (75)	4350 (30)	14500 (100)	80
4 " (101,6)	4,6"-5,12" (117-130)	3,46" (88)	4350 (30)	14500 (100)	100
4 1/2" (114,3)	5,5"-6,3" (140-160)	3,85" (98)	4350 (30)	14500 (100)	120
5 " (127)	5,9"-6,3" (150-160)	4,25" (108)	4350 (30)	14500 (100)	150
5 1/2" (139,7)	6,61"-9,05" (168-230)	4,76" (121)	4350 (30)	14500 (100)	180
5 3/4" (146)	6,61"-9,05" (168-230)	5" (127)	4350 (30)	14500 (100)	190
6 5/8" (168,3)	7,68"-9,05" (195-230)	5,94" (151)	4350 (30)	14500 (100)	200
7" (178)	8,46"-9,05" (215-230)	6,25" (159)	4350 (30)	14500 (100)	200
9 5/8" (244,5)	11,61"-12,79" (295-325)	8,85" (225)	3625 (25)	13050 (90)	250

* design dimensions can be changed and manufactured to individual technological conditions of the customer's well

Hydraulic packer string liner hanger PL-LH/PHSG

is designed for suspension and sealing of casing sections, "liners", in pre-lowered casing after cementing or without cementing of the well. During casing string fastening it ensures its straightness during cement slurry setting thus preventing unloading on cement stone, effectively influencing contact of cement stone with casing string and reliable sealing of inter-casing space, excluding overflow of formation fluids during well operation. Liners hanger PL-LH/PHSG is used for both vertical and directional wells and can be combined with various process equipment.

A stop collar, plug or ball for it is delivered together with the suspension, depending on the technological features of the well.

DESIGN ADVANTAGES:

- lowering and anchoring wells in difficult geological conditions;
- independent activation of hanger and packer elements;
- reliable fixation of packers from axial movement;
- wide working pressure range;
- reliability and ease of use.

Casing, in / (mm)	Installation range in / (mm)	Inner diameter max.in / (mm)	Maximum pressure, psi / (MPa)		Permissible pressure drop on the rubber elements of the packer, MPa	Load capacity, t
			Activation	Testing		
3 1/2" (88,9)	4,6"-5,12" (117-130)	2,95" (75)	4350 (30)	14500 (100)	10150 (70)	80
4 " (101,6)	4,6"-5,12" (117-130)	3,46" (88)	4350 (30)	14500 (100)	10150 (70)	100
4 1/2" (114,3)	5,5"-6,3" (140-160)	3,85" (98)	4350 (30)	14500 (100)	10150 (70)	120
5 " (127)	5,9"-6,3" (150-160)	4,25" (108)	4350 (30)	14500 (100)	10150 (70)	150
5 1/2" (139,7)	6,61"-9,05" (168-230)	4,76" (121)	4350 (30)	14500 (100)	10150 (70)	180
5 3/4" (146)	6,61"-9,05" (168-230)	5" (127)	4350 (30)	14500 (100)	10150 (70)	190
6 5/8" (168,3)	7,68"-9,05" (195-230)	5,94" (151)	4350 (30)	14500 (100)	10150 (70)	200
7" (178)	8,46"-9,05" (215-230)	6,25" (159)	4350 (30)	14500 (100)	8700 (60)	200
9 5/8" (244,5)	11,61"-12,79" (295-325)	8,85" (225)	3625 (25)	13050 (90)	7250 (50)	250



* design dimensions can be changed and manufactured to individual technological conditions of the customer's well

Hydraulic double-gripping packer liner hanger PL-LH/HDG

is designed for suspension and sealing of casing string section "liners" in pre-lowered casing string after cementing or without cementing the well. While anchoring casing provides its straightness during cement slurry setting thereby preventing unloading on cement stone, effectively affecting contact of cement stone with casing and reliable sealing of inter-casing space, excluding overflow of formation fluids during well operation. PL-LH/HDG liners hanger is used for both vertical and directional wells and can be combined with various process equipment.

A stop collar and a plug or ball under the hanger is supplied with the hanger, depending on the technological features of the well.

DESIGN ADVANTAGES:

- lowering and anchoring of wells in difficult geological and technological conditions;
- independent activation of anchor and packer units;
- reliable fixation of packers from upward and downward axial movement;
- wide working pressure range;
- reliability and ease of use.

Casing, in / (mm)	Installation range in / (mm)	Inner diameter max.in / (mm)	Maximum pressure, psi / (MPa)		Permissible pressure drop on the rubber elements of the packer, MPa	Load capacity, t
			Activation	Testing		
3 1/2" (88,9)	4,6"-5,12" (117-130)	2,95" (75)	4350 (30)	14500 (100)	10150 (70)	80
4 " (101,6)	4,6"-5,12" (117-130)	3,46" (88)	4350 (30)	14500 (100)	10150 (70)	100
4 1/2" (114,3)	5,5"-6,3" (140-160)	3,85" (98)	4350 (30)	14500 (100)	10150 (70)	120
5 " (127)	5,9"-6,3" (150-160)	4,25" (108)	4350 (30)	14500 (100)	10150 (70)	150
5 1/2" (139,7)	6,61"-9,05" (168-230)	4,76" (121)	4350 (30)	14500 (100)	10150 (70)	180
5 3/4" (146)	6,61"-9,05" (168-230)	5" (127)	4350 (30)	14500 (100)	10150 (70)	190
6 5/8" (168,3)	7,68"-9,05" (195-230)	5,94" (151)	4350 (30)	14500 (100)	10150 (70)	200
7" (178)	8,46"-9,05" (215-230)	6,25" (159)	4350 (30)	14500 (100)	8700 (60)	200
9 5/8" (244,5)	11,61"-12,79" (295-325)	8,85" (225)	3625 (25)	13050 (90)	7250 (50)	250

* design dimensions can be changed and manufactured to individual technological conditions of the customer's well



Liners hanger hydraulic double-grip packer double-row casing PL-LH/HD2G

is designed for suspension and sealing of casing section of considerable weight in pre-lowered casing after cementing. When securing casing, it ensures its straightness during setting of cement slurry, thus preventing unloading on cement stone, effectively affecting contact of cement stone with casing and reliable sealing of inter-casing space, making it impossible to overflow formation fluids during drilling operation. Liners hanger PL-LH/HD2G is used for both vertical and directional wells and can be combined with various process equipment.

A stop collar and plug or ball under the hanger is supplied with the hanger, depending on the technological features of the well.

DESIGN ADVANTAGES:

- lowering and securing wells in difficult geological and technological conditions;
- suspension of significant weight sections;
- anchor assembly fixation during installation;
- reliable fixation of rams from upward and downward axial movement;
- wide working pressure range;
- high strength characteristics;
- reliability and ease of use.

Casing, in / (mm)	Installation range in / (mm)	Inner diameter max.in / (mm)	Maximum pressure, psi / (MPa)		Permissible pressure drop on the rubber elements of the packer, MPa	Load capacity, t
			Activation	Testing		
3 1/2" (88,9)	4,6"-5,12" (117-130)	2,95" (75)	4350 (30)	14500 (100)	10150 (70)	80
4 " (101,6)	4,6"-5,12" (117-130)	3,46" (88)	4350 (30)	14500 (100)	10150 (70)	100
4 1/2" (114,3)	5,5"-6,3" (140-160)	3,85" (98)	4350 (30)	14500 (100)	10150 (70)	120
5 " (127)	5,9"-6,3" (150-160)	4,25" (108)	4350 (30)	14500 (100)	10150 (70)	150
5 1/2" (139,7)	6,61"-9,05" (168-230)	4,76" (121)	4350 (30)	14500 (100)	10150 (70)	180
5 3/4" (146)	6,61"-9,05" (168-230)	5" (127)	4350 (30)	14500 (100)	10150 (70)	190
6 5/8" (168,3)	7,68"-9,05" (195-230)	5,94" (151)	4350 (30)	14500 (100)	10150 (70)	200
7" (178)	8,46"-9,05" (215-230)	6,25" (159)	4350 (30)	14500 (100)	8700 (60)	200
9 5/8" (244,5)	11,61"-12,79" (295-325)	8,85" (225)	3625 (25)	13050 (90)	7250 (50)	250

* design dimensions can be changed and manufactured to individual technological conditions of the customer's well



Liner hanger packer mechanical PL-LH/PMSG

is designed to suspend a casing section in a previously run casing pre-lowered casing after cementing or without cementing of the well. When cementing casing, it ensures its straightness during setting of cement slurry, thus preventing unloading on cement stone, effectively affecting contact of cement stone with casing.

Liner hanger PL-LH/PMSG is used for both vertical and directional wells and is combined with various process equipment. Liner hanger is activated by a 2-4 turn to the right, followed by unloading.

The PL-LH/PMSG pendant is used and is compatible with a variety of process equipment.

DESIGN ADVANTAGES:

- lowering and cementing wells in difficult geological and technological conditions;
- independent activation of anchor and packer units;
- allows carrying out casing in different intervals of the well;
- reliable fixation of packers from axial downward movement;
- wide working pressure range;
- reliability and ease of use.

Casing, in / (mm)	Installation range in / (mm)	Inner diameter max.in / (mm)	Maximum pressure test, psi / (MPa)	Permissible pressure drop on the rubber elements of the packer, MPa	Load capacity, t
3 1/2" (88,9)	4,6"-5,12" (117-130)	2,95" (75)	14500 (100)	10150 (70)	80
4" (101,6)	4,6"-5,12" (117-130)	3,46" (88)	14500 (100)	10150 (70)	100
4 1/2" (114,3)	5,5"-6,3" (140-160)	3,85" (98)	14500 (100)	10150 (70)	120
5" (127)	5,9"-6,3" (150-160)	4,25" (108)	14500 (100)	10150 (70)	150
5 1/2" (139,7)	6,61"-9,05" (168-230)	4,76" (121)	14500 (100)	10150 (70)	180
5 3/4" (146)	6,61"-9,05" (168-230)	5" (127)	14500 (100)	10150 (70)	190
6 5/8" (168,3)	7,68"-9,05" (195-230)	5,94" (151)	14500 (100)	10150 (70)	200
7" (178)	8,46"-9,05" (215-230)	6,25" (159)	14500 (100)	8700 (60)	200
9 5/8" (244,5)	11,61"-12,79" (295-325)	8,85" (225)	13050 (90)	7250 (50)	250



* design dimensions can be changed and manufactured to individual technological conditions of the customer's well

Liner hanger mechanical PL-LH/MSG

is designed to suspend casing section "liner" in pre-lowered casing after cementing or without cementing of the well. While cementing casing provides its straightness during cement slurry setting thus preventing unloading on cement slurry. PL-LH/MSG is also used for partially unloading tubing. PL-LH/MSG is installed in both vertical and directional wells and is compatible with various process equipment. It is activated by tensioning the string for 1-2 m and then turning it 1-2 turns to the right followed by unloading it by required value.

DESIGN ADVANTAGES:

- lowering and cementing wells in difficult geological and technological conditions;
- allows to perform cementing in different intervals of the well; reliable fixation of rams from downward axial movement;
- wide working pressure range;
- easy deactivation;
- reliability and ease of use.

Casing, in / (mm)	Installation range in / (mm)	Inner diameter max.in / (mm)	Maximum pressure test, psi / (MPa)	Load capacity, t
3 1/2" (88,9)	4,6"-5,12" (117-130)	2,95" (75)	14500 (100)	80
4 " (101,6)	4,6"-5,12" (117-130)	3,46" (88)	14500 (100)	100
4 1/2" (114,3)	5,5"-6,3" (140-160)	3,85" (98)	14500 (100)	120
5 " (127)	5,9"-6,3" (150-160)	4,25" (108)	14500 (100)	150
5 1/2" (139,7)	6,61"-9,05" (168-230)	4,76" (121)	14500 (100)	180
5 3/4" (146)	6,61"-9,05" (168-230)	5" (127)	14500 (100)	190
6 5/8" (168,3)	7,68"-9,05" (195-230)	5,94" (151)	14500 (100)	200
7" (178)	8,46"-9,05" (215-230)	6,25" (159)	14500 (100)	200
9 5/8" (244,5)	11,61"-12,79" (295-325)	8,85" (225)	13050 (90)	250



* design dimensions can be changed and manufactured to individual technological conditions of the customer's well

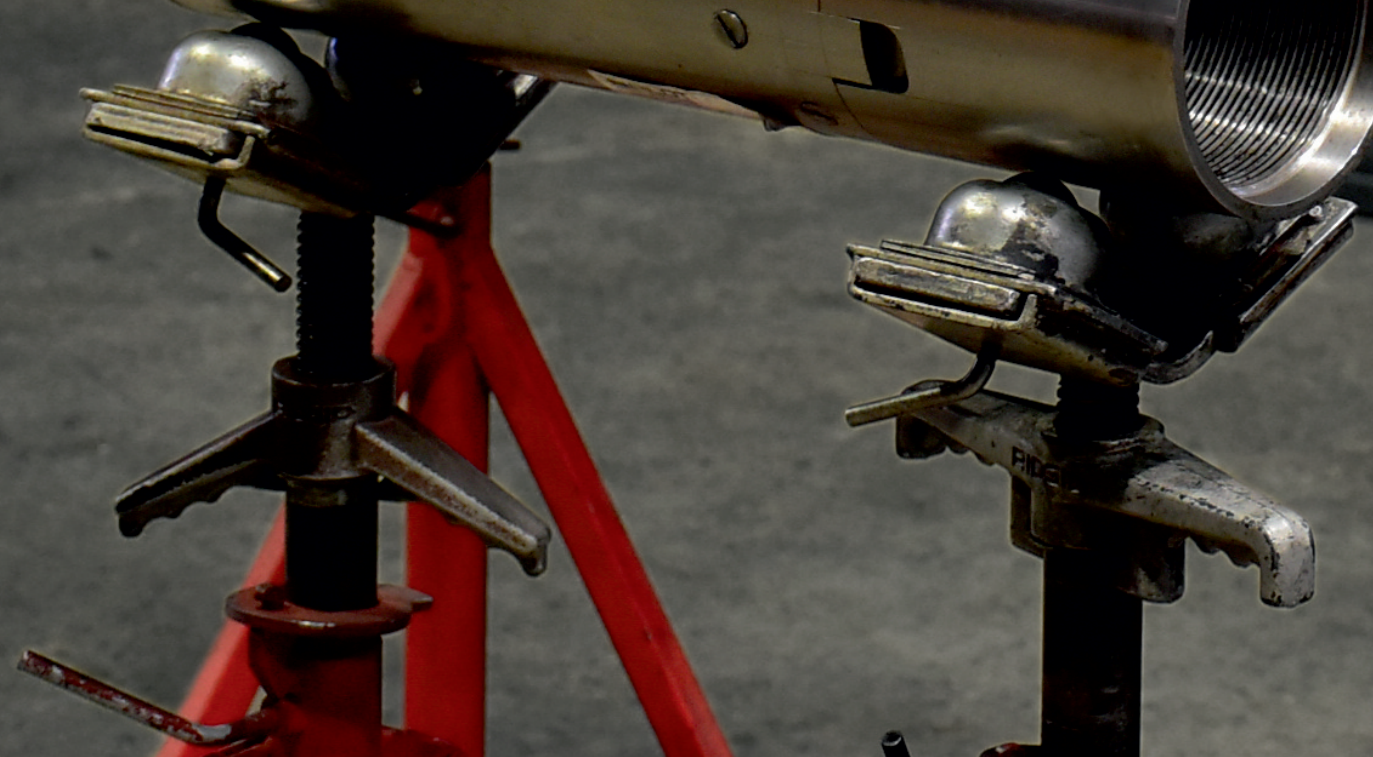
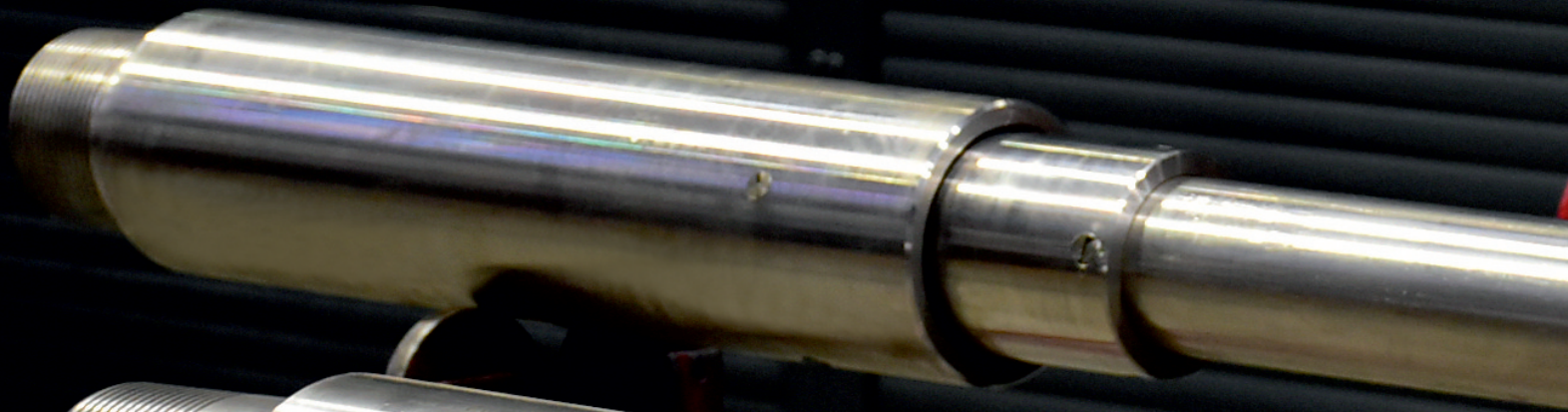



Casing
disconnect tool

Hydraulic disconnecter PL-HRT

is designed for running and fastening of casing "liner". This disconnecter design allows you to rotate and axial move the liner string by an acceptable value.

The PL-HRT disconnecter is used for both vertical and directional wells. Is used with various technological equipment mainly together with hangers, with a low weight of the casing "liner".

The disconnection of the drill pipe from the casing "liner" is carried out by creating a predetermined value of the activation pressure.

A "stop collar" and a drill pipe plug or ball are supplied with the disconnecter.

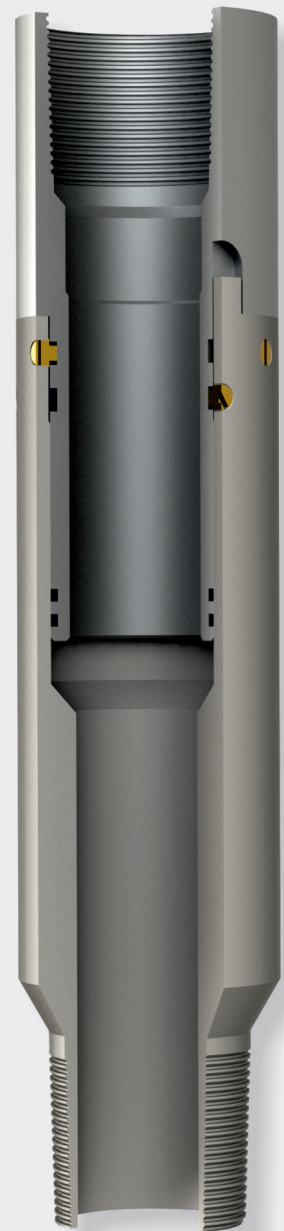

DESIGN ADVANTAGES:

- running and fastening of wells in difficult geological and technological conditions;
- can by rotation in the process of running;
- reliability and ease of use.

Casing, in /(mm)	Tooling sizes, in /(mm)		Maximum pressure, psi / (MPa)		Load capacity, t
	Outer diameter max.	Inner diameter min.	Activation	Testing	
3 1/2" (88,9)	4,64" (118)	2,95" (75)	4350 (30)	14500 (100)	30
4 " (101,6)	4,64" (118)	3,38" (86)	4350 (30)	14500 (100)	30
4 1/2" (114,3)	5,9" (150)	3,81" (97)	4350 (30)	14500 (100)	30
5 " (127)	5,9" (150)	4,05" (103)	4350 (30)	14500 (100)	30
5 1/2" (139,7)	7,08" (180)	4,60" (117)	4350 (30)	14500 (100)	35
5 3/4" (146)	7,08" (180)	4,88" (124)	4350 (30)	14500 (100)	35
6 5/8" (168,3)	7,71" (196)	5,66" (144)	4350 (30)	14500 (100)	45
7 " (178)	7,71" (196)	6,06" (154)	4350 (30)	14500 (100)	45
7 5/8" (193,6)	8,34" (212)	6,61" (168)	3625 (25)	13050 (90)	50

* design dimensions can be changed and manufactured to individual technological conditions of the customer's well

Hydraulic disconnecter PL-HRTRH

is designed for running and fastening of casing "liner". This disconnecter design allows you to rotate and axial move the liner string by an acceptable value.

The PL-HRTRH disconnecter is used for both vertical and directional wells. Is used with various technological equipment mainly together with hangers, and "stop" assemblies with a low weight of the casing "liner". Disconnection the running tool after all technological operations is carried out by by creating a predetermined value of activation pressure. In case of failure to achieve tightness, the left cross-over is turned away by rotating the drilling string to the right.

A "stop collar" and a drill pipe plug or ball are supplied with the disconnecter.

DESIGN ADVANTAGES:

- running and fastening in difficult geological and technological conditions;
- availability of the duplicate method of disconnection;
- anti-rotational execution of closing plug and they fixation;
- reliability and ease of use.

Casing, in /(mm)	Tooling sizes, in /(mm)		Maximum pressure, psi / (MPa)		Load capacity, t
	Outer diameter max.	Inner diameter min.	Activation	Testing	
3 1/2" (88,9)	4,64" (118)	2,95" (75)	4350 (30)	14500 (100)	30
4 " (101,6)	4,64" (118)	3,38" (86)	4350 (30)	14500 (100)	30
4 1/2" (114,3)	5,9" (150)	3,81" (97)	4350 (30)	14500 (100)	30
5 " (127)	5,9" (150)	4,05" (103)	4350 (30)	14500 (100)	30
5 1/2" (139,7)	7,08" (180)	4,60" (117)	4350 (30)	14500 (100)	35
5 3/4" (146)	7,08" (180)	4,88" (124)	4350 (30)	14500 (100)	35
6 5/8" (168,3)	7,71" (196)	5,66" (144)	4350 (30)	14500 (100)	45
7 " (178)	7,71" (196)	6,06" (154)	4350 (30)	14500 (100)	45
7 5/8" (193,6)	8,34" (212)	6,61" (168)	3625 (25)	13050 (90)	50



* design dimensions can be changed and manufactured to individual technological conditions of the customer's well

The disconnecter hydraulic – mechanical PL-H/MRT

designed for running and cementing of casing "liner". When fastening the well casing, it ensures its straightness in the process of wait on cement, thereby preventing unloading on cement stone. PL-H/ MRT disconnecter is used for both vertical and directional wells and is assembled with various technological equipment. The disconnecter can be equipped keying to allow the column to rotate during the run in process.

Activation of the PL-H/MRT disconnecter is carried out after all the necessary technological operations are carried out by creating the pressure value necessary for opening the flushing holes with further mechanical disconnection of the well string "liner" from the drill pipes.

A "stop collar" and a drill pipe plug or ball are supplied with the disconnecter.

DESIGN ADVANTAGES:

- the running and fastening of wells in difficult geological conditions; the presence of a duplicate option for opening flushing holes;
- to the construction possibility of ensuring the rotation during the running well casing;
- anti-rotational execution of closing plug and they fixation;
- run casing of high weight;
- broad range of working pressure;
- reliability and ease of use.

Casing, in /(mm)	Tooling sizes, in /(mm)		Maximum pressure, psi / (MPa)		Load capacity, t
	Outer diameter max.	Inner diameter min.	Activation	Testing	
3 1/2" (88,9)	4,64" (118)	2,95" (75)	4350 (30)	14500 (100)	40
4 " (101,6)	4,64" (118)	3,38" (86)	4350 (30)	14500 (100)	55
4 1/2" (114,3)	5,9" (150)	3,81" (97)	4350 (30)	14500 (100)	75
5 " (127)	5,9" (150)	4,05" (103)	4350 (30)	14500 (100)	80
5 1/2" (139,7)	7,08" (180)	4,60" (117)	4350 (30)	14500 (100)	85
5 3/4" (146)	7,08" (180)	4,88" (124)	4350 (30)	14500 (100)	95
6 5/8" (168,3)	7,71" (196)	5,66" (144)	4350 (30)	14500 (100)	100
7" (178)	7,71" (196)	6,06" (154)	4350 (30)	14500 (100)	110
7 5/8" (193,6)	8,34" (212)	6,61" (168)	3625 (25)	13050 (90)	140



* design dimensions can be changed and manufactured to individual technological conditions of the customer's well

Hydraulic disconnecter PL-HRTM

is designed for running and cementing of casing "liner" of high weight. This disconnecter design allows the descent in difficult geological conditions of the well where axial movements reach critical values and the ability to control the process of cementing the casing well and his finished. The PL-H/MRT disconnecter is used for both vertical and directional wells and is used with various technological equipment. Activation of the PL-H/MRT disconnecter is carried out after all the necessary technological operations are carried out by creating the pressure value necessary for activate the piston, thereby releasing the collet grip and disconnecting the liner from the casing. In case of failure to achieve tightness, the adapter of the left is turned away by rotating the drilling string to the right.

A "stop collar" and a drill pipe plug or ball are supplied with the disconnecter.

DESIGN ADVANTAGES:

- availability of an alternative method of disconnection using the left thread;
- broad range of working pressure;
- reliability and ease of use;
- anti-rotational execution of closing plug and they fixation.

Casing, in / (mm)	Tooling sizes, in / (mm)		Maximum pressure, psi / (MPa)		Load capacity, t
	Outer diameter max.	Inner diameter min.	Activation	Testing	
3 1/2" (88,9)	4,64" (118)	2,95" (75)	4350 (30)	14500 (100)	40
4 " (101,6)	4,64" (118)	3,38" (86)	4350 (30)	14500 (100)	55
4 1/2" (114,3)	5,9" (150)	3,81" (97)	4350 (30)	14500 (100)	75
5 " (127)	5,9" (150)	4,05" (103)	4350 (30)	14500 (100)	80
5 1/2" (139,7)	7,08" (180)	4,60" (117)	4350 (30)	14500 (100)	85
5 3/4" (146)	7,08" (180)	4,88" (124)	4350 (30)	14500 (100)	95
6 5/8" (168,3)	7,71" (196)	5,66" (144)	4350 (30)	14500 (100)	100
7" (178)	7,71" (196)	6,06" (154)	4350 (30)	14500 (100)	110
7 5/8" (193,6)	8,34" (212)	6,61" (168)	3625 (25)	13050 (90)	140

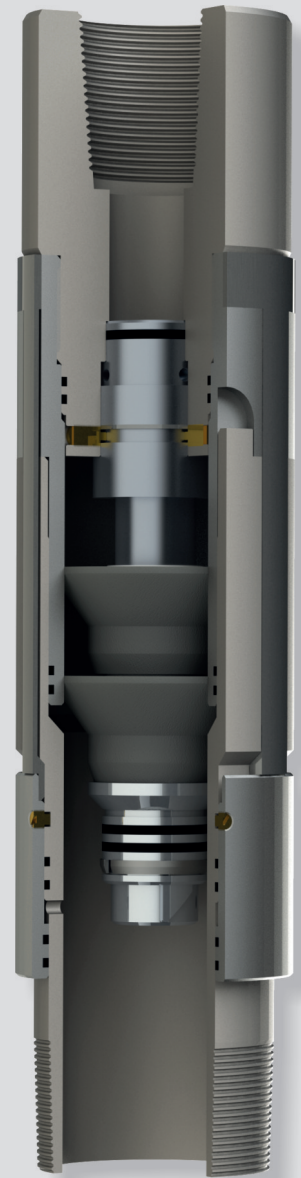

* design dimensions can be changed and manufactured to individual technological conditions of the customer's well

The mechanical disconnecter PL-MRT

is designed for running and cementing the well casing. When fastening the well casing, it ensures its straightness in the process of wait on cement, thereby preventing unloading on cement stone. The PL-H/MRT disconnecter can be equipped keying, that block the premature disconnection from the running casing pipes, which allows, in particularly difficult conditions, to perform the tolerance of the liner with rotation. The PL-H/MRT disconnecter is used for both vertical and directional wells and is assembled with various technological equipment. Opening of the flushing holes and disconnection is carried out by rotating the allowable tool in the right to the required number of turns.

A "stop collar" and a drill pipe plug or ball are supplied with the disconnecter.

DESIGN ADVANTAGES:

- the running and fastening of wells in difficult geological conditions; with secures control over the cementing process and is given in the
- high cement sleeve;
- possibility of running and fastening of casing columns without the use
- hanger for well casing;
- disconnection method with left thread;
- this is the mentation of sections in a stretched state;
- section casing cementing in tension;
- duplicating option for opening flushing holes;
- constructional options that provide for the possibility of rotation of the section during the descent process.

Casing, in / (mm)	Tooling sizes, in / (mm)		Maximum pressure, psi / (MPa)		Load capacity, t
	Outer diameter max.	Inner diameter min.	Cementing	Testing	
4 1/2" (114,3)	5,9" (150)	3,81" (97)	4350 (30)	14500 (100)	120
5 " (127)	5,9" (150)	4,05" (103)	4350 (30)	14500 (100)	150
5 1/5" (139,7)	7,67" (195)	4,60" (117)	4350 (30)	14500 (100)	180
5 3/4" (146)	7,67" (195)	4,88" (124)	4350 (30)	14500 (100)	190
6 5/8" (168,3)	8,38" (213)	5,66" (144)	4350 (30)	14500 (100)	200
7" (178)	8,38" (213)	6,06" (154)	4350 (30)	14500 (100)	200
9 5/8" (244,5)	12" (305)	8,54" (217)	3625 (25)	13050 (90)	250
12 3/4" (323,9)	14,84" (377)	11,73" (298)	2900 (20)	7250 (50)	300
13 3/8" (339,7)	15,43" (392)	12,63" (321)	2900 (20)	6530 (45)	300



* design dimensions can be changed and manufactured to individual technological conditions of the customer's well

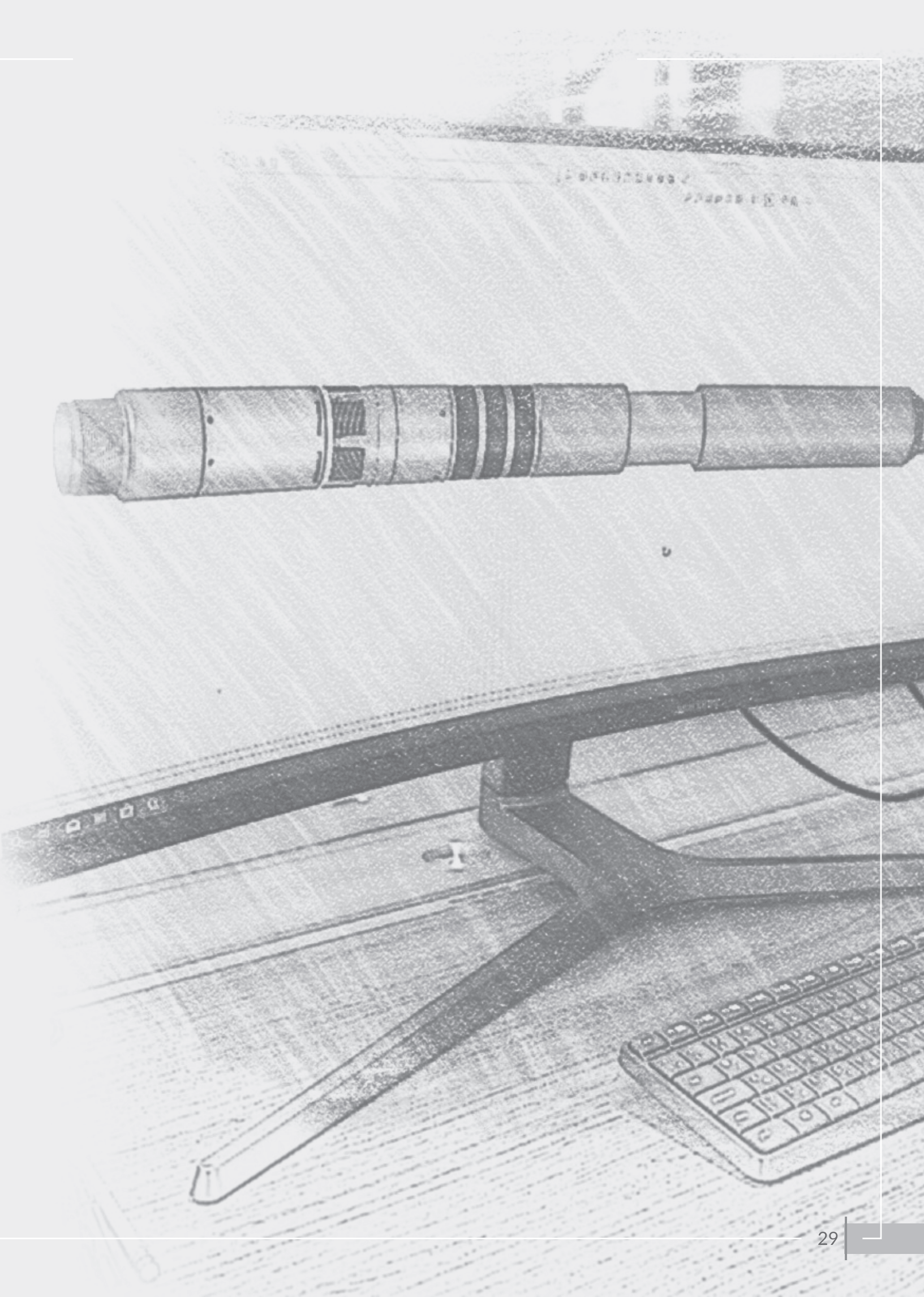





External casing packer

Hydraulic casing packer PL-PHME

is designed to seal the casing space and is part of the casing liner assembly. The packer is activated by applying pressure to the required value. Once activated, a piston compresses the rubber elements to the desired dimensions, sealing the inter-casing space. The packer has a locking system that allows the rubber elements to remain compressed after the pipes are depressurized.

The packer is supplied with a "stop collar" sleeve, plug or ball under it, depending on the technological features of the operation.



DESIGN ADVANTAGES:

- lowering and securing wells in difficult geological conditions;
- possibility of installation in open borehole and casing string;
- wide working pressure range; reliability and ease of operation;
- packer element retention system.

Casing, in / (mm)	Installation range in / (mm)	Inner diameter max.in / (mm)	Maximum pressure, psi / (MPa)		Permissible pressure drop on the rubber elements of the packer, MPa	Load capacity, t
			Activation	Testing		
3 1/2" (88,9)	4,6"-5,12" (117-130)	2,95" (75)	4350 (30)	14500 (100)	10150 (70)	80
4 " (101,6)	4,6"-5,12" (117-130)	3,38" (86)	4350 (30)	14500 (100)	10150 (70)	100
4 1/2" (114,3)	5,5"-6,3" (140-160)	3,81" (97)	4350 (30)	14500 (100)	10150 (70)	120
5 " (127)	5,9"-6,3" (150-160)	4,05" (103)	4350 (30)	14500 (100)	10150 (70)	150
5 1/2" (139,7)	6,61"-9,05" (168-230)	4,60" (117)	4350 (30)	14500 (100)	10150 (70)	180
5 3/4" (146)	6,61"-9,05" (168-230)	4,88" (124)	4350 (30)	14500 (100)	10150 (70)	190
6 5/8" (168,3)	7,68"-9,05" (195-230)	5,66" (144)	4350 (30)	14500 (100)	10150 (70)	200
7" (178)	8,46"-9,05" (215-230)	6,06" (154)	4350 (30)	14500 (100)	8700 (60)	200
9 5/8" (244,5)	11,61"-12,79" (295-325)	8,54" (217)	3625 (25)	13050 (90)	7250 (50)	250

Packer hydraulic External PL-PME

is used with an emphasis on the bottom of the well and is designed to seal its bottomhole space. It is included in the layout of the technological equipment of the casing string "liner". The packer is activated by creating an axial thrust of the drill pipe string. The packer has a locking system that allows leaving the rubber elements in the activated state after the axial load is removed.

DESIGN ADVANTAGES:

- running and well casing in difficult geological and technological conditions;
- possibility of installation in the open hole and in casing strings;
- under a wide range of conditions of working pressure value;
- reliability and ease of use;
- system of fixing the packer unit.



Casing, in / (mm)	Installation range in / (mm)	Inner diameter max.in / (mm)	Maximum pressure, psi / (MPa)	Permissible pressure drop on the rubber elements of the packer, MPa	Load capacity, t
3 1/2" (88,9)	4,6"-5,12" (117-130)	2,95" (75)	14500 (100)	10150 (70)	80
4 " (101,6)	4,6"-5,12" (117-130)	3,38" (86)	14500 (100)	10150 (70)	100
4 1/2" (114,3)	5,5"-6,3" (140-160)	3,81" (97)	14500 (100)	10150 (70)	120
5 " (127)	5,9"-6,3" (150-160)	4,05" (103)	14500 (100)	10150 (70)	150
5 1/2" (139,7)	6,61"-9,05" (168-230)	4,60" (117)	14500 (100)	10150 (70)	180
5 3/4" (146)	6,61"-9,05" (168-230)	4,88" (124)	14500 (100)	10150 (70)	190
6 5/8" (168,3)	7,68"-9,05" (195-230)	5,66" (144)	14500 (100)	10150 (70)	200
7" (178)	8,46"-9,05" (215-230)	6,06" (154)	14500 (100)	8700 (60)	200
9 5/8" (244,5)	11,61"-12,79" (295-325)	8,54" (217)	13050 (90)	7250 (50)	250

* design dimensions can be changed and manufactured for individual technological conditions of the Customer's well

Packer hydraulic PL-PH

is designed to check the technical condition of production casing strings and wellheads by their pressure testing. The use of the hydraulic packer allows in case of leakage of the production casing to determine the location and depth of leakage by interval pressure testing of the casing. Reliable design provides easy installation and removal of the packer. Transferring the packer to the transport position is carried out by removing excess pressure.

DESIGN ADVANTAGES:

- simplicity and reliability of design;
- possibility of installation at different depths;
- multiple installation and removal.

Casing, in / (mm)	Installation range in / (mm)	Maximum pressure test, psi / (MPa)	Permissible pressure drop on the rubber elements of the packer, MPa	Load capacity, t
5 1/2" (139,7)	4,37"-5,01" (111-127)	7250 (50)	5000 (35)	180
5 3/4" (146)	4,9"-5,14" (124-130)	7250 (50)	5000 (35)	190
6 5/8" (168,3)	5,67"-6,13" (144-155)	7250 (50)	5000 (35)	200
7" (178)	5,92"-6,36" (150-161)	7250 (50)	5000 (35)	200
9 5/8" (244,5)	8,53"-9" (216-229)	7250 (50)	5000 (35)	250



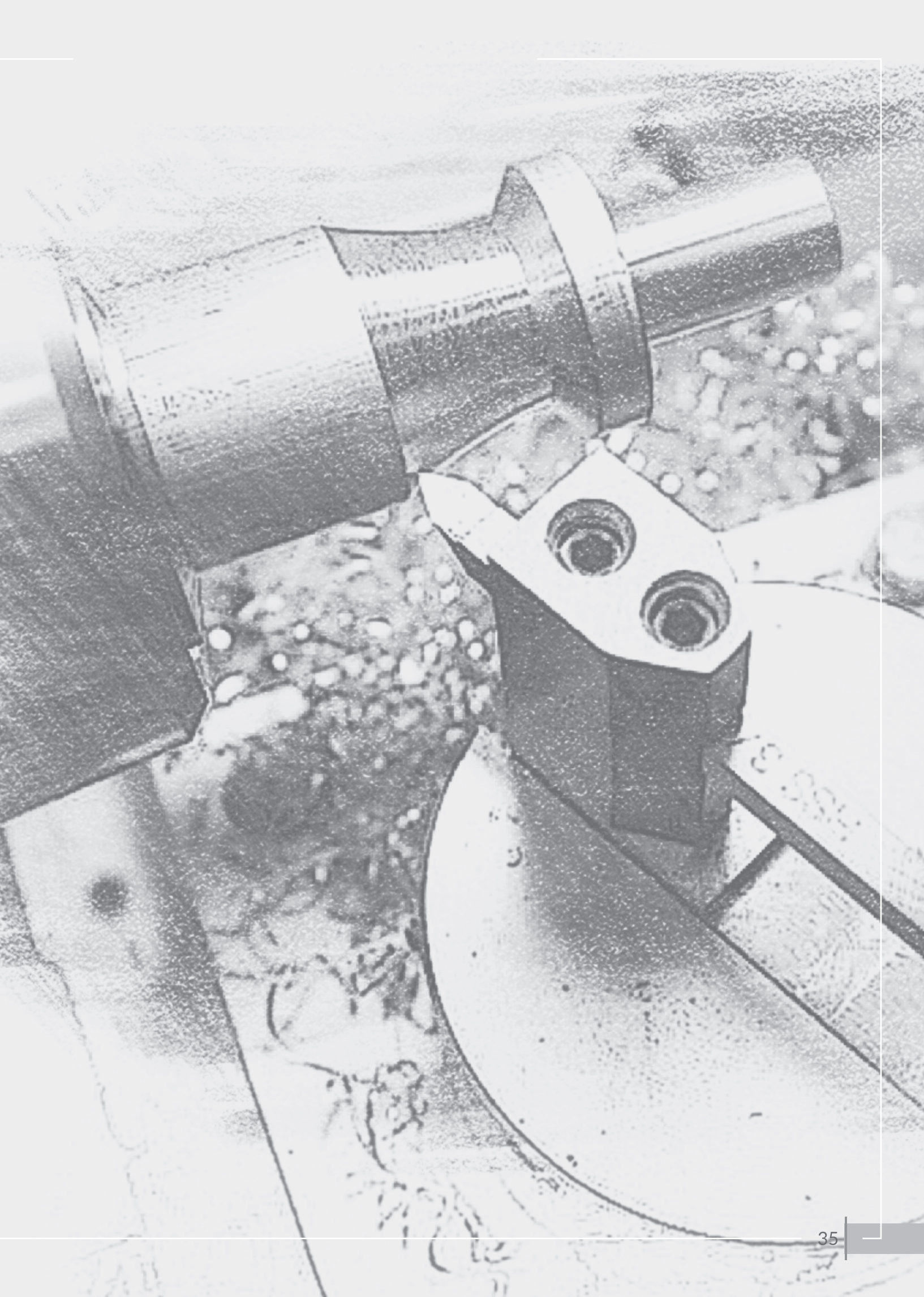

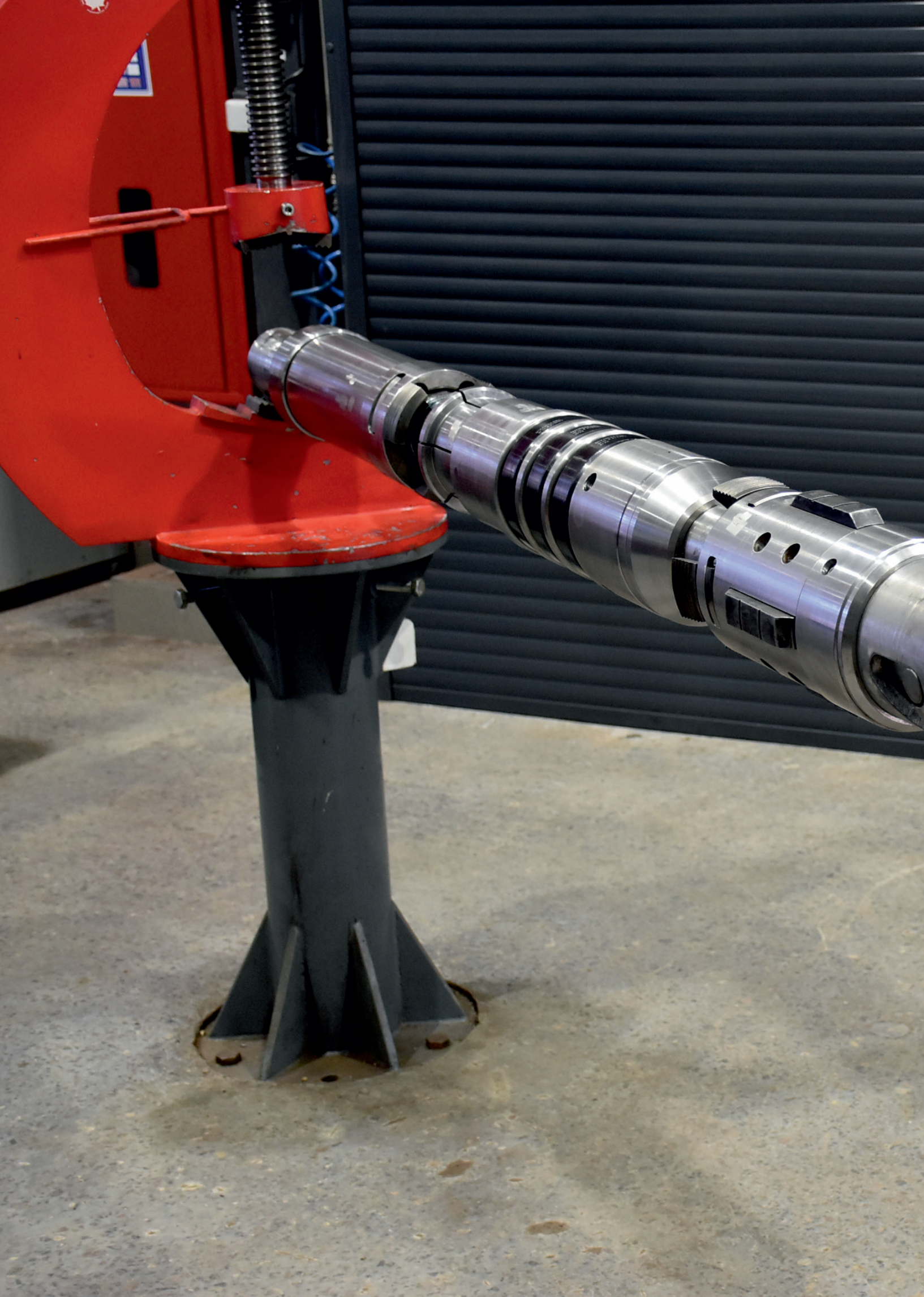



Downhole equipment

Packer PI1- X

is designed for hermetic separation of two zones of the wellbore and isolation of the work pipes during the operation of oil, gas and gas condensate wells. It can be used together with other technological equipment for various types of well stimulation and formation testing. The double grip model of the production packer allows its installation compression or tension-set production the work pipes and the ability to hold differential pressure from above or below. The packer is designed to be removable, allowing for pressure release above and below the packer and easy removal of the top anchors. The J-slot design allows for easy installation and removal with 1/4 turn to the right on the packer for installation and 1/4 turn to the right on the packer for removal.



DESIGN ADVANTAGES:

- Holds high pressure differentials from above or below packer.
- Can be set using tension or compression.
- Field-proven releasing system.
- Reliability of construction.

Casing		Recommended Hole Size		Packer Size		Thread Connection		
Size (in)/(mm)	Weight (lbs/ft) / (kg/m)	Min. I.D. (in)/ (mm)	Max I.D. (in)/ (mm)	O.D. (in)/ (mm)	I.D. (in)/ (mm)			
4 1/2" (114,3)	15,1 (22,47)	3,826 (95,352)	3,826 (97,180)	3,650 (91,288)	1,938 (49,225)	2 3/8" EUE		
	9.5-13.5 (14,137-20,09)	3,920 (99,568)	4,090 (103,886)	3,750 (95,250)				
5" (127,0)	18.0-20.8 (26,79-30,95)	4,156 (105,562)	4,276 (108,610)	4,000 (101,6)				
	13.5-15.1 (20,09-22,47)	4,408 (11,963)	4,560 (114,452)	4,125 (104,775)				
5 1/2" (139,7-146,0)	20.0-23.0 (29,76-34,23)	4,670 (118,62)	4,778 (121,36)	4,500 (114,3)			2,375 (60,3)	2 7/8" EUE
	14.0-20.0 (20,83-29,76)	4,778 (121,36)	5,044 (127,3)	4,625 (117,5)				
	20.0-23.0 (29,76-34,23)	4,670 (118,62)	4,778 (121,36)	4,500 (114,3)				
	14.0-20.0 (20,83-29,76)	4,778 (121,36)	5,012 (127,3)	4,625 (117,5)				
6 5/8" (168,3)	24.0-32.0 (35,7-47,6)	5,675 (144,15)	5,921 (150,4)	5,500 (139,7)	3,000 (76,2)	3 1/2" EUE		
	24.0-32.0 (35,7-47,6)	5,675 (144,15)	5,921 (150,4)	5,500 (139,7)				
7" (177,8)	26.0-32.0 (38,69-47,6)	6,094 (154,79)	6,276 (159,41)	5,875 (149,2)	2,375 (60,3)	2 7/8" EUE		
	26.0-32.0 (38,69-47,6)	6,094 (154,79)	6,276 (159,41)	5,875 (149,2)			3,000 (76,2)	3 1/2" EUE

Packer PL- C

is designed for hermetic separation of two zones of the wellbore of the isolation of the working string of pipes during the operation of oil, gas and gas condensate wells, as well as for other technological operations. The simplicity and reliability of the design provides an easy process of installing and removing the packer, the ability to include the packer in more complex arrangements when performing well completion operations using two or more packers. The ability to adjust the force to install the packer directly in the well conditions.

DESIGN ADVANTAGES:

- Design reliability assurance.
- Compact design.
- The design allows easy setting and releasing.
- Controlled feature of packer in under downhole conditions.

Casing		Recommended Hole Size		Packer Size		Thread Connection	
Size (in)/(mm)	Weight (lbs/ft) / (kg/m)	Min. I.D. (in)/ (mm)	Max I.D. (in)/ (mm)	O.D. (in)/ (mm)	I.D. (in)/ (mm)		
4 1/2" (114,3)	15,1 (22,47)	3,826 (95,352)	3,826 (97,180)	3,650 (91,288)	1,938 (49,225)	2-3/8" EUE	
	9.5-13.5 (14,137-20,09)	3,920 (99,568)	4,090 (103,886)	3,750 (95,250)			
5" (127,0)	18.0-20.8 (26,79-30,95)	4,156 (105,562)	4,276 (108,610)	4,000 (101,6)			
	13.5-15.1 (20,09-22,47)	4,408 (11,963)	4,560 (114,452)	4,125 (104,775)			
5 1/2" (139,7-146,0)	20.0-23.0 (29,76-34,23)	4,670 (118,62)	4,778 (121,36)	4,500 (114,3)		2,375 (60,3)	2-7/8" EUE
	14.0-20.0 (20,83-29,76)	4,778 (121,36)	5,044 (127,3)	4,625 (117,5)			
	20.0-23.0 (29,76-34,23)	4,670 (118,62)	4,778 (121,36)	4,500 (114,3)			
	14.0-20.0 (20,83-29,76)	4,778 (121,36)	5,012 (127,3)	4,625 (117,5)			
6 5/8" (168,3)	24.0-32.0 (35,7-47,6)	5,675 (144,15)	5,921 (150,4)	5,500 (139,7)	3,000 (76,2)	3-1/2" EUE	
	24.0-32.0 (35,7-47,6)	5,675 (144,15)	5,921 (150,4)	5,500 (139,7)			
7" (177,8)	26.0-32.0 (38,69-47,6)	6,094 (154,79)	6,276 (159,41)	5,875 (149,2)	2,375 (60,3)	2-7/8" EUE	
	26.0-32.0 (38,69-47,6)	6,094 (154,79)	6,276 (159,41)	5,875 (149,2)			3,000 (76,2)



Model "PT-2" On-Off Tool

is designed for lowering and safe disconnection of tubing string from the packer. The main components of the disconnecter are: overshoot, fixed on the tubing string and stinger. The overshoot is released from the stinger by rotating the tubing string to the left by 1/4 turn in the standard version. It can include (optionally) an internal profile for installing a blanking plug, which allows isolating the subpacker zone. The presence of an overshoot shoe in the design of the disconnecter ensures its centering and movement in the polluted space.

DESIGN ADVANTAGES:

- Allows to disconnect the tubing without removing the packer.
- Allows to carry out pressuer tests.
- Easy disconnection process.
- Possibility of use as a blanking plug, if there is a landing profile in the stinger.
- High strength parameters.

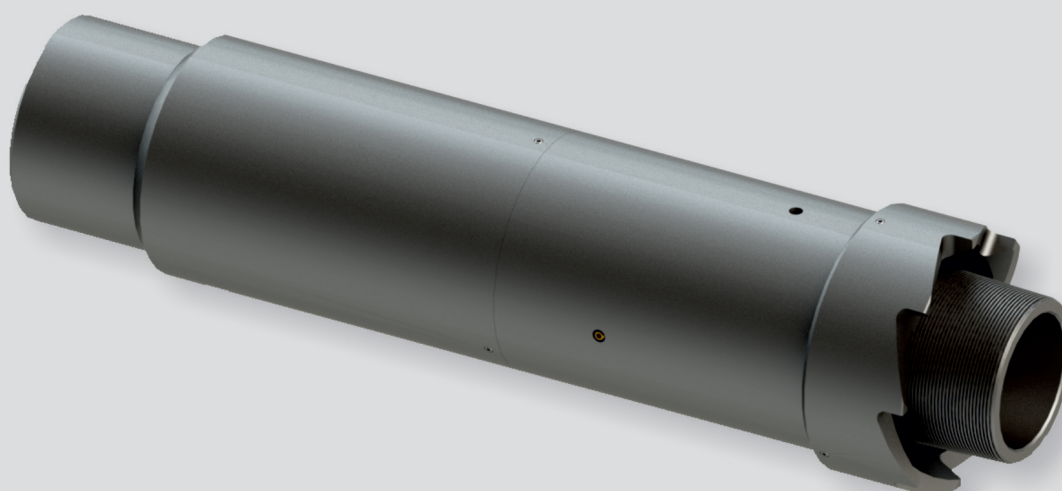

On-Off Tool Size (inches)	Max OD of On-Off Tool (inches /mm)	Max ID of On-Off Tool (inches /mm)	Standard Thread Connection Box x Pin
5" x 2-7/8"	3.750 (95,25)	1.875 (47,62)	2-3/8" (60,3) EUE
5-1/2" x 2-7/8"	4.500 (114,3)	2.50 (63,50)	2-7/8" (73,0) EUE
6-5/8" x 2-7/8"	5.500 (139,7)	2.50 (63,50)	2-7/8" (73,0) EUE
7" x 2-7/8"	5.875 (149,25)	2.50 (63,50)	2-7/8" (73,0) EUE/ 3-1/2" (88,9) EUE

*Threaded connections and geometric dimensions can be changed at the request of the Customer

The Latch Seal the permanent packer (Permapack)

is designed for hermetic connection of a column of pipes with a permanent packer that is pre-installed. The design of the Latch provides for its reliable tight connection with the packer due to the threaded collet and sealing nipple. An additional impenetrable shoulder is provided, providing a positive stop of the anchor in the top of the packer.

DESIGN ADVANTAGES:

- simple procedure of connection with the packer;
- easy disconnection of the packer from the tubing string;
- high sealing properties of sealing elements.



*Threaded connections and geometric dimensions can be changed at the request of the Customer

Sliding Sleeve PL-XA (SSD)

The device is designed to connect the pipe space with the casing space by moving the inner sleeve, which can be opened or closed using standard tools on cable equipment or coiled tubing. Holes in the inner sleeve provide pressure equalization between the tubing and casing space when the valve is opened. The PXA circulation valve is opened upwards using a tool to move the sleeve. The PXA circulation valve can be used to direct flow from tubing space to tubular space in selective layout. Other applications include killing wells, performing acid treatments and hydraulic fracturing, or equalizing pressure between isolated formations and a tubing string.

DESIGN ADVANTAGES:

- Compact and simple proven design that is cost effective and reliable, with a long service life.
- Manufactured of 4140 alloy steel and Viton elastomers as standard.
- Selective nipples of the PLX profile for installation of tools running with the wireline technique.



Model PXA Sliding Sleeve										
Seal Bore ID		Flow Area (Ports)		Flow Area (Min ID)		Max OD		Thread Box x Pin	Shifting Tool	Max Working Pressure (psi)
in.	mm.	Sq in.	Sq cm.	Sq in.	Sq cm.	in.	mm.			
1.875	47.25	2.355	15.19	2.762	17.82	3.063	77.80	2-3/8" EUE	1.875 "B"	8,000
2.313	58.26	3.974	25.64	4.199	27.09	3.668	93.17	2-7/8" EUE	2.312 "B"	10,000
1.875	47.25	2.355	15.19	2.762	17.82	3.063	77.80	2-3/8" EUE	1.875 "B"	8,000

*Threaded connections and geometric dimensions can be changed at the request of the Customer

Hydraulic Circulation Valve PL-CVH

is designed to connect the pipe space with the casing space of the well by creating an overpressure in the working string of pipes. After the pressure is released, the valve returns to the closed position. Other applications include well killing, acid treatments or pressure equalization between isolated formations and tubing string.

DESIGN ADVANTAGES:

- Communication between the tubing string and the casing by creating excessive pressure.
- After the pressure is released, the hydraulic circulation valve is returned to the closed position.
- Compact and simple proven design that is cost effective and reliable, with a long service life.

Tool Size (inches /mm)	Tool OD (inches /mm)	Tool ID (inches /mm)	Thread Connection
2 3/8" (60,3)	3.06 (77,0)	2.00 (50,8)	2-3/8 EUE
2 7/8" (73,0)	3.67 (93,2)	2.50 (63,5)	2-7/8 EUE
3 1/2" (89,0)	4.5 (114,3)	3.00 (76,2)	3-1/2 EUE

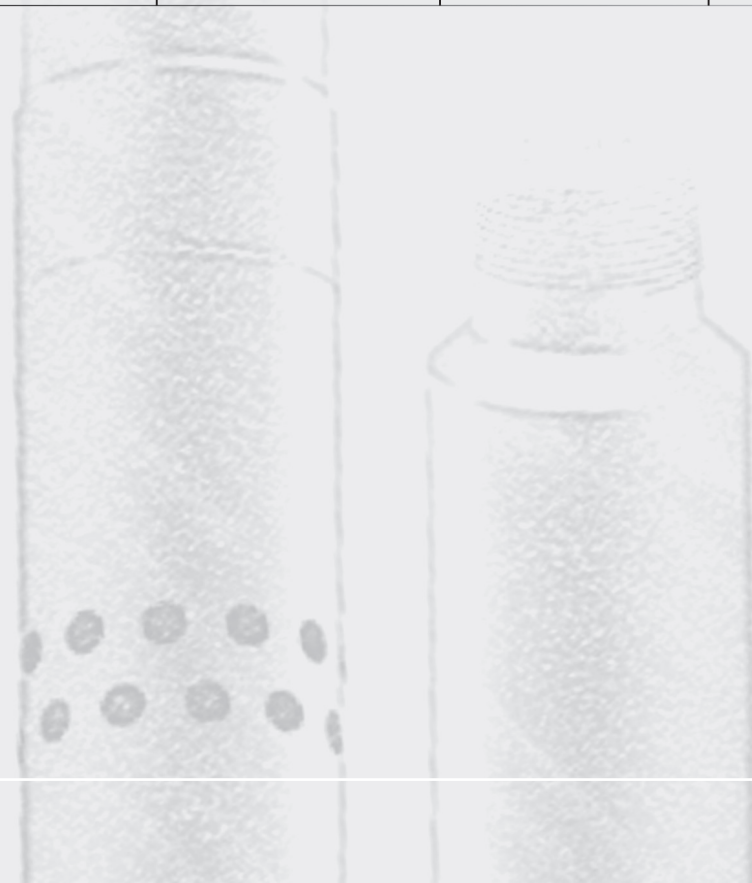

Depression differential sub PL-DS

The single or twin port-less is used in perforating systems to provide an economical method of achieving the required depression between the tubing string and the well formation. The device includes a high-strength ceramic dome-shaped cup (or two dome-shaped cups), preventing communication between the tubing and annular space prior to discharge from the surface of the initiating rod. The dome cup holds pressure up to 10,000 psi below the device (in the twin design, pressure is held above and below the device). A depression differential sub is installed in the tubing string, typically above or below the packer to create the required depression, and prevents fluid from entering the tubing string.

DESIGN ADVANTAGES:

- Economical alternative to profile nipple with a BLANKING PLUG.
- Full-bore opening the inner diameter after ceramic dome are removed.
- Application as a barrier for activation of hydraulic equipment.
- High temperature properties.
- Allows for tubing tests up to 10,000psi (68.9MPa).
- Application in the environment with H₂S and CO₂.

Tubing Size (inches / mm)	Tool OD (inches / mm)	Tool ID (inches / mm)	WORKING PRESSURE PSI / MPa
2 3/8" (60,3)	3.34 (85)	1.97 (50)	10,000 PSI (68,9 MPa)
2 7/8" (73,0)	3.67 (93,2)	2.50 (63,5)	10,000 PSI (68,9 MPa)
3 1/2" (89,0)	4.5 (114,3)	3.00 (76,2)	10,000 PSI (68,9 MPa)



*Threaded connections and geometric dimensions can be changed at the request of the Customer

Landing nipples PLX and PL-XN

Allow you to place a variety of devices for regulating the flow of liquid.

The Landing nipples have an internal sealing channel and a profile for connection to the locking device and its fixing. The sealing channels and locking profiles are made in such a way that they fit with various connecting systems and are available in full bore and reduced cross-section versions to provide a reliable positive stop for flow control devices.

The seats are sized to match the tubing diameters and the sealing channel diameters are available to accommodate different wall thicknesses and connection systems.

PL-XN nipples is used as the bottom element of the tubing column. It contains a stop belt (No-Go), which prevents the passage of devices through it.

The most common profiles of "Otis" landing nipples are produced.



DESIGN ADVANTAGES:

- The presence of a polished sealing channel.
- High strength characteristics.

Tubing Size		PLX				PLXN			
		Ø Min. Nipple I.D.		Ø Seal Bore		Ø Min. Nipple I.D.		Ø Seal Bore	
in.	mm.	in.	mm.	in.	mm.	in.	mm.	in.	mm.
2 3/8"	60,3	1,875	47,63	1,875	47,63	1,791	45,59	1,875	47,63
2 7/8"	73,0	2,313	58,75	2,313	58,75	2,205	56,01	2,313	58,75
3 1/2"	88,9	2,750	69,85	2,750	69,85	2,635	67,75	2,750	69,85
		2,812	71,42	2,812	71,42	2,660	67,56	2,812	71,42

*Threaded connections and geometric dimensions can be changed at the request of the Customer

SAFETY SUB (shear type) PL-SS

is designed for disconnecting from the equipment in case of seizure of the working of pipes. The release of the working column occurs due to the axial tension of the pipe above its own weight to the shearing force of the pins. If necessary, the design of safety sub makes it possible to transmit torque to downstream equipment.

To ensure the required strength characteristics, steels of high strength groups are used in the manufacture of this type of equipment.

DESIGN ADVANTAGES:

- Possibility of disconnection by axial tension of pipes above their own weight.
- Transmit torque to the equipment installed below.

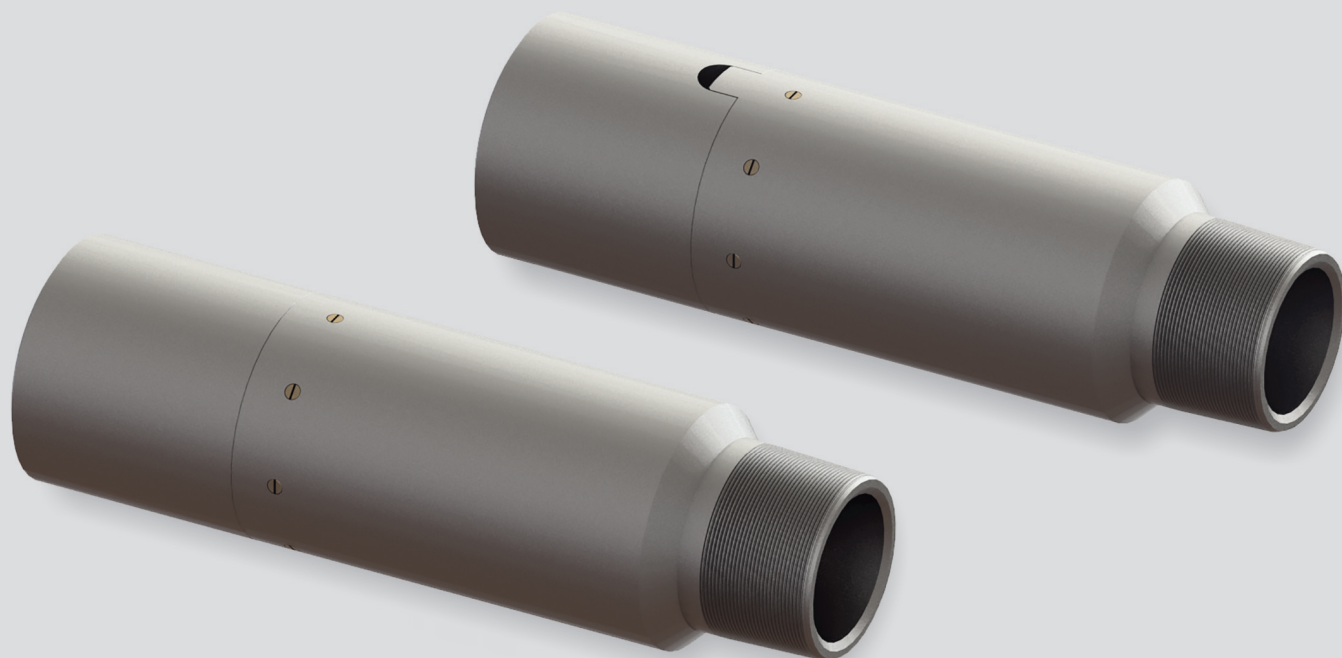

SIZE (inches /mm)	TOOL OD (inches /mm)	TOOL ID (inches /mm)	Thread connection BOX x PIN
2 3/8" (60,3)	3.34 (85)	1.97 (50)	At the request of the Customer
2 7/8" (73,0)	3.67 (93,2)	2.50 (63,5)	At the request of the Customer
3 1/2" (89,0)	4.5 (114,3)	3.00 (76,2)	At the request of the Customer
4 1/2" (114,3)	5.56 (141,2)	4.00 (101,6)	At the request of the Customer
5 1/2" (139,7)	6.00 (152,4)	5.13 (130,3)	At the request of the Customer

*Threaded connections and geometric dimensions can be changed at the request of the Customer

Pump-out Plug PL-POP

The pump-out plug is installed in the lower part of the pipe string and is designed to isolate the pipe space from the annulus and activate the hydraulic equipment installed above the device by creating an overpressure. To deactivate the pump-out plug, a pressure value is created in the tubular space, providing a full-bore opening the inner.

DESIGN ADVANTAGES:

- Possibility to adjust the pressure values for activation and deactivation in the field.
- Simplicity and reliability of design.
- High strength characteristics.



Tubing Size (inches /mm)	TOOL OD (inches /mm)	TOOL ID (inches /mm)	Thread Connection (standard version)
2 3/8" (60,3)	3.06 (77,0)	2.00 (50,8)	2-3/8" EUE
2 7/8" (73,0)	3.67 (93,2)	2.50 (63,5)	2-7/8" EUE
3 1/2" (89,0)	4.5 (114,3)	3.00 (76,2)	3-1/2" EUE
4 1/2" (114,3)	5.56 (141,2)	4.00 (101,6)	At the request of the Customer
5 1/2" (139,7)	6.00 (152,4)	5.13 (130,3)	At the request of the Customer

*Threaded connections and geometric dimensions can be changed at the request of the Customer

Casing Scraper (mechanical) PL-CS

is designed to clean the inner walls of casing strings from clay crust, cement stone, paraffin, salt crystals and their compounds, solid iron oxides that can cause casing corrosion. Cleaning or preparation of certain intervals of casing strings is an important process for the operation of all tools used in drilling or workover operations. Cleaning of the inner surface is performed along the entire length of the casing string or its defined intervals by axial movement of the tool (downward stroke) with continuous or periodic circulation of flushing fluid to carry cleaning products to the surface.

DESIGN ADVANTAGES:

- Provides coverage of the entire inner diameter of the casing string.
- Provides free washing out of the removed sludge.
- The possibility of passing the scraper in places with a reduced inner diameter of the casing and in the intervals of well curvature.



Parameters	4 1/2" 114,3 mm	5" 127 mm	5 1/2" 140 -146 mm	6 5/8" 168,3 mm	7" 177,8 mm	9 5/8" 244,5 mm
TOOL BASIC O.D.	86	98	108	136	143	200
Tool OD	18	25	32	32	32	67
LENGTH	660	660	750	990	990	1010
Max. O.D. of blades	106	116	130	166	167	230
Min OD Blades (in the constructed position)	86	98	108	136	145	200
Tool Joint Connection	2 3/8 Reg	2 3/8 Reg	2 7/8 Reg	3 1/2 Reg	3 1/2 Reg	NC-46 (4 IF)*
Blades number	6	6	6	6	6	8
Spring number	30	30	30	36	36	48

*Threaded connections and geometric dimensions can be changed at the request of the Customer

Casing Drift PL-CD

is designed for drifting the production string before running the equipment and checking the internal diameter of the string, simulating the equipment in length and outer diameter. As templating elements, aluminum bushings are used, which have longitudinal grooves for the possibility of fluid circulation during the run. Unlike steel, the use of aluminum bushings provides easier release of the drift when wedging in the casing, and is also more informative in the presence of damage or changes in the internal diameter of the casing.

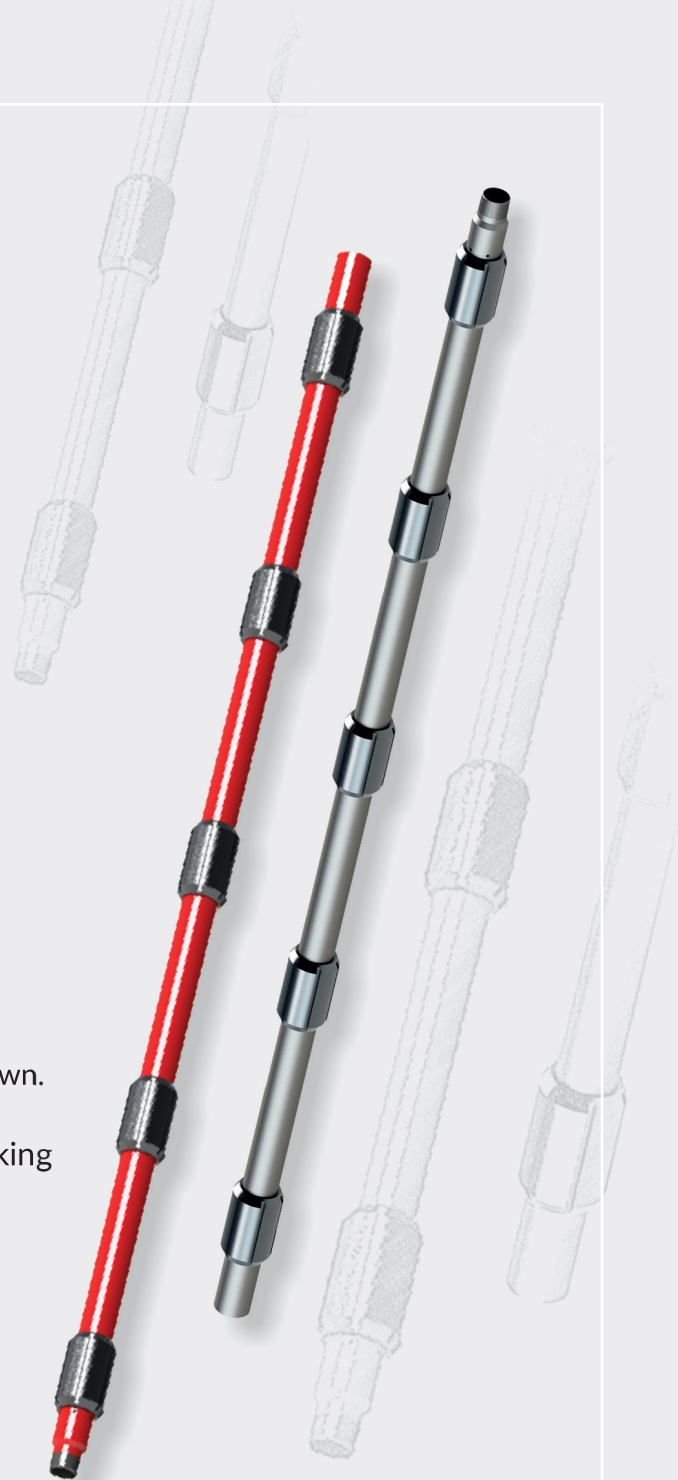

DESIGN ADVANTAGES:

- Capability to simulate smaller downhole equipment.
- Possibility of fluid circulation during in the time of going down.
- Determine damaged casing intervals.
- Possibility of templating by axial movement of the working pipes.

Parameters	Ø 104 mm	Ø 115 mm	Ø 118 mm	Ø 140 mm	Ø 150 mm
Recommended casing size	5"	5 1/2"	5 1/2"	6 5/8"	7"
I.D. drift (mm.)	54	54	54	54	54
Length (mm.)	2400	2400	2400	2400	2400
Thread connections	2 7/8"EUE	2 7/8"EUE	2 7/8"EUE	2 7/8"EUE	2 7/8"EUE
Aluminum elements number	5	5	5	5	5

*Threaded connections and geometric dimensions can be changed at the request of the Customer

Depth Ejector Jet Pump PL-DEP

is designed for use in oil, gas and gas condensate fields, as equipment for lifting the formation fluid of the well during its operation by jetting units in the gas-lift-jet method of operation. The purpose of which is to clean the bottomhole zones of formations, restore their filtration properties and obtain an inflow of formation products.

The jetting devices of stationary or insert type are used, which are based on the principle of ejector operation.

DESIGN ADVANTAGES:

It is used in the operation of wells in difficult geological and technological conditions, which include:

- deep depth;
- low reservoir pressure at productive sediments of field;
- high content of liquid phase in the extracted products (oil wells);
- high viscosity of well products (water-oil emulsions or pure oil) ;
- inflow of mechanical impurities from the formation into the well;
- deposits of resins, salts, paraffin in the production system



Support-unloading device SUD

is designed to reduce the load of part of the weight of the tubing string on the casing string. ORM is made of high-alloy steel, longitudinal grooves allow the circulation of flushing fluid. ORM is installed on the support device included in the casing string or on the top part of the linerhanger.

DESIGN ADVANTAGES:

- Possibility of flushing fluid circulation due to structurally provided longitudinal grooves.
- High strength characteristics.
- Simplicity and reliability of design.

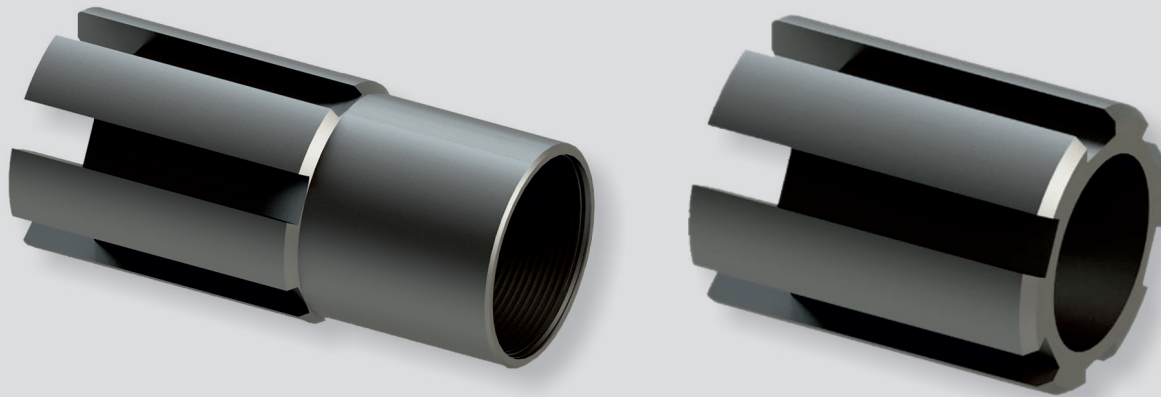

Crossover PL-C

of any complexity with different connecting threads, which are used for hermetic connection of equipment layout elements or casing elements. The crossovers can be used under difficult geological conditions (high formation pressures, abnormally high temperatures, aggressive environments, etc.). To ensure the required strength characteristics, steel of different strength groups are used.

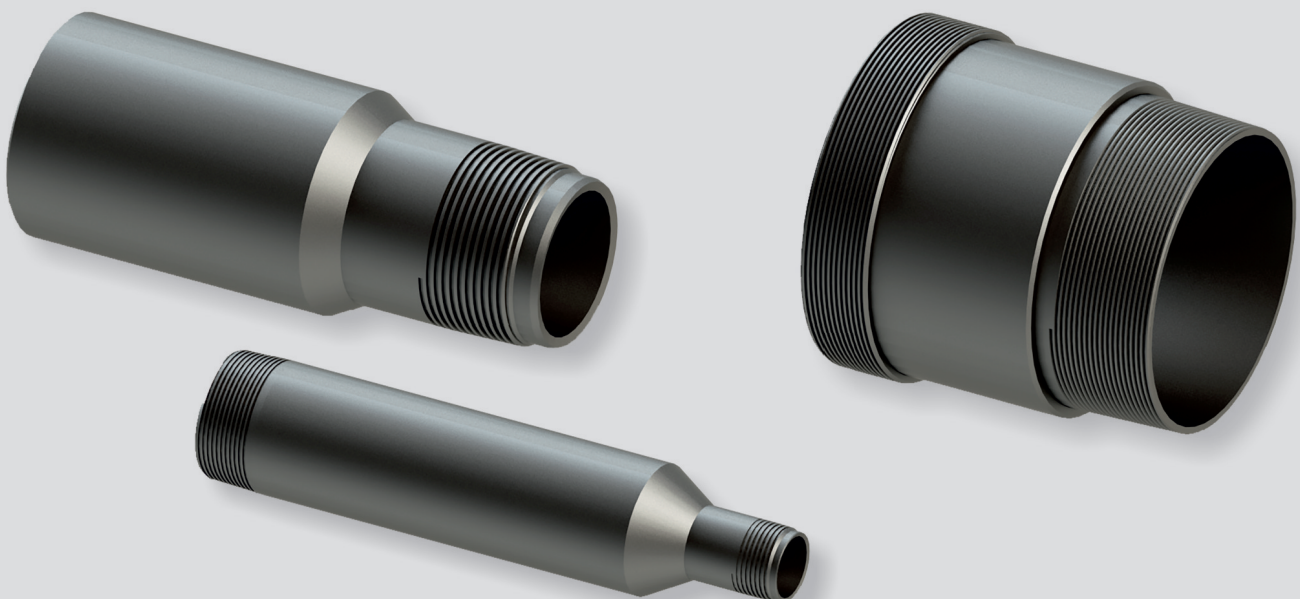

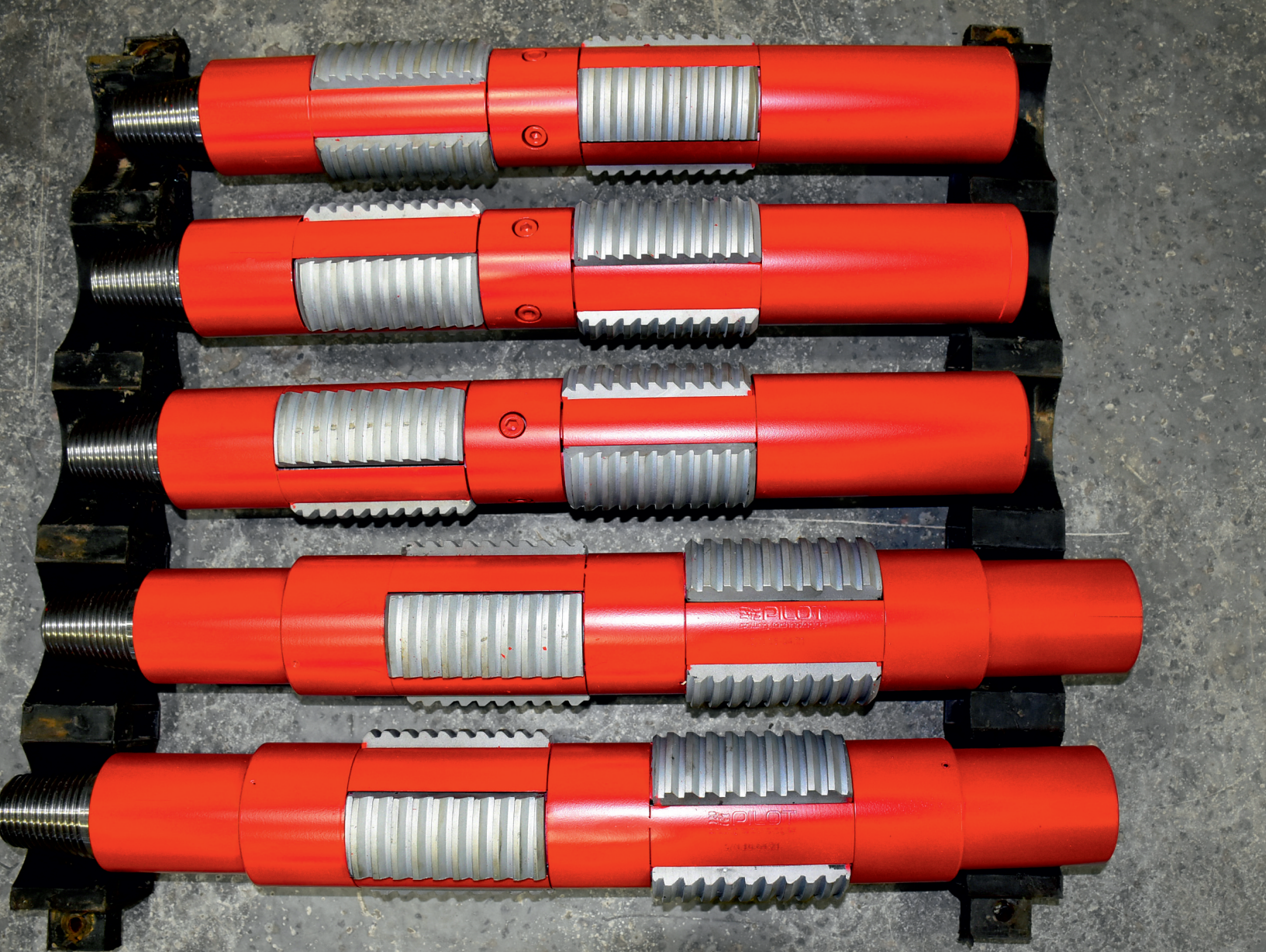



Auxiliary equipment

Stinger PL-St

is used for cementing casing strings of large diameters through working drill pipes. It saves time on these works by reducing the volume of pumping fluid and increases the technological safety of works.

A separate drill pipe plug is supplied with the Stinger PL-St.

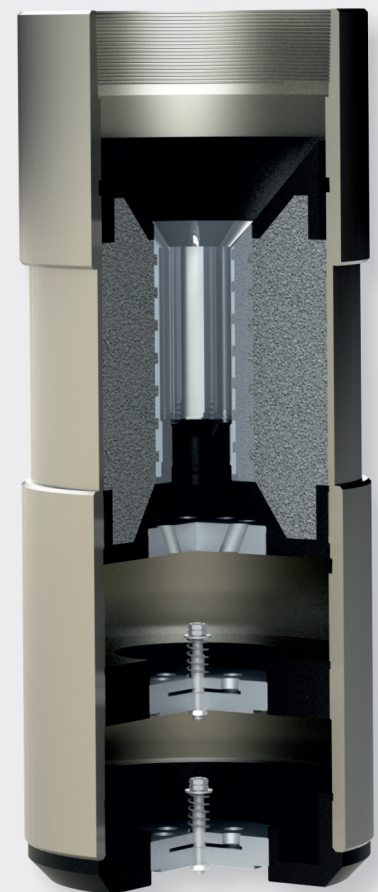
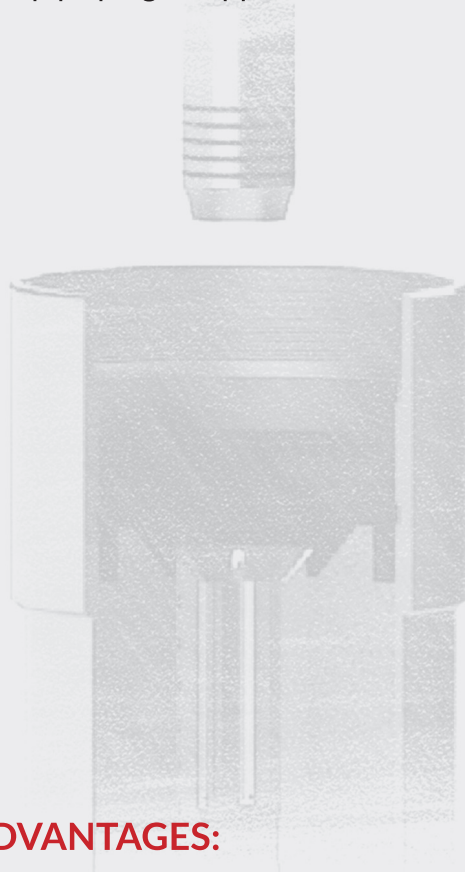

DESIGN ADVANTAGES:

- provides control over the cementing process;
- possibility of disconnection using the left thread;
- possibility of installing both a single and a double valve.

Casing, in / (mm)	Equipment Size ,in / (mm)		MAX pressure, psi / (MPa)		Load capacity,t
	Max O.D. (in) / (mm)	Min I.D. (in) / (mm)	Cementing	Experiment	
12 3/4" (323,9)	14,84" (377)	11,73" (298)	2900 (20)	4350 (30)	300
13 3/8" (339,7)	15,43" (392)	12,63" (321)	2900 (20)	4350 (30)	300
16" (406,4)	17" (431,8)	15,37" (390,5)	2900 (20)	4350 (30)	300
16 3/4" (425,45)	17,75" (451)	15,96" (405,38)	2900 (20)	4350 (30)	300
18 5/8" (473,08)	20" (508)	17,75" (450,98)	2900 (20)	4350 (30)	300
20" (508)	21" (533,4)	19,12" (485,64)	2900 (20)	4350 (30)	300

Cementing head PL-CH

is designed for cementing the lower and middle sections of casing strings during sectional fastening of the well and cementing of casing strings "liner" using the top dart-plug or ball.

It is completed with two high-pressure ball valve and a filter. It is used with an acceptable drilling tool with a diameter of 73 mm to 147 mm.



DESIGN ADVANTAGES:

- possibility of starting the dart-plug without stopping the cementing process;
- allows, with the dart-plug installed in it, to circulate the well;
- fixing the dart-plug;
- reliability and ease of use.

Max O.D. (in) / (mm)	Permissible cementing pressure, psi / (MPa)	Load capacity, t	Connection threads
8.18" (208)	7250/50	300	3-133 (4 ½ IF) 3-147 (5 ½ FH)

Cementing head PL-CHB

are designed for the duty of oil and gas well for the purpose of:

- quick-connect and hermetic
- connection of casing string with high-pressure line of cementing units or drilling pumps;
- preliminary fixation and release cement displacement plug and wiper sectional cementing plugs and control elements (plugs "BOMB");
- control of the flow of buffer fluid, drilling and tamponage mud in relation to the displacement plug and wiper sectional cementing plugs .

DESIGN ADVANTAGES:

- plug start control;
- fast and unhindered release of plugs; equalization of hydrostatic pressure
- under and above the plugs; quick-connect thread with cementing
- head and casing.

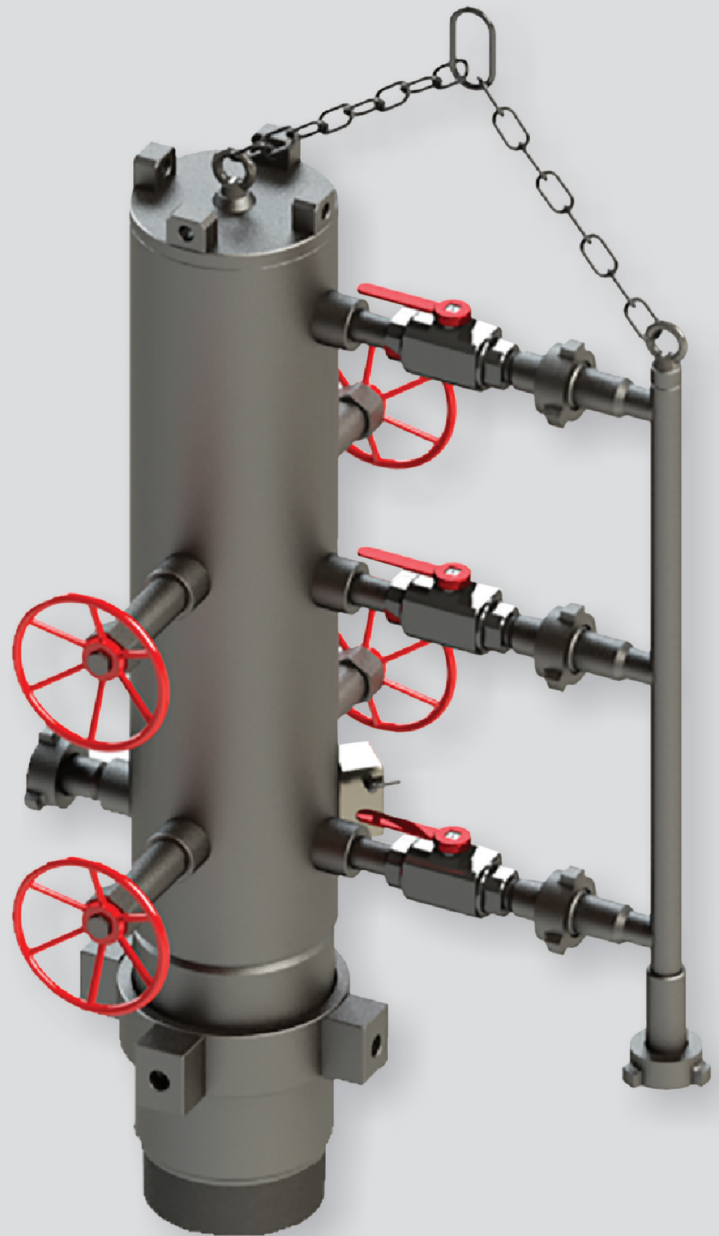

Size, in / (mm)	Geometric dimension in / (mm)		Distance between the support pins in / (mm)	Max working pressure psi / (MPa)
	Max O.D. (in) / (mm)	Min I.D. (in) / (mm)		
5 1/2"-5 3/4" (139,7-146,05)	6,61" (168)	5,03" (128)	15,74" (400)	7250 (50)
6 5/8"-7" (168,3-177,8)	7,87" (200)	6,29" (160)	16,53" (420)	7250 (50)
9 5/8" (244,5)	10,78" (274)	9,64" (245)	17,71" (450)	5800 (40)
12 3/4"-13 3/8" (323,8-339,7)	14,9" (380)	13,38" (340)	19,68" (500)	2900 (20)

Float valve PL-SV

the Superflapflow type valve provides reliable sealing of the inner tubing space, and is designed for pumping fluids with high performance during continuous operation and with colmatating additives. Valve parts are made of easily drillable material, which allows full drilling with PC bits. Special coating and rubberization of the plunger makes this valve wear-resistant and reliable for sealing.

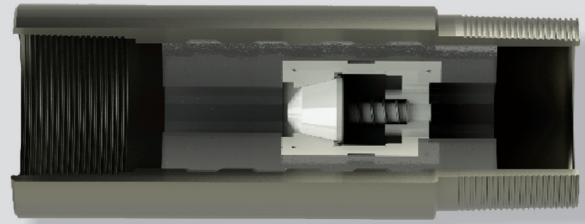

Shoe PL-S

string with a guide nozzle is designed to equip the lower part of the casing string in order to guide and increase its passage through the wellbore, and to prevent deformation of the lower pipe during landings.

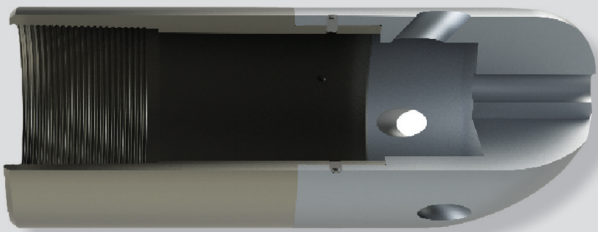

Float shoe PL-FS

is designed to equip the bottom of pipe casing strings in order to guide them along the wellbore and protect them from damage when running into the well. And also to prevent the reverse movement of the cement slurry into the tubular space after its pushing.

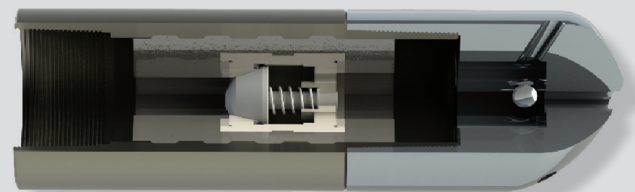

Casing, in / (mm)	Max O.D. (in) / (mm)	Min I.D. (in) / (mm)	Maximum back pressure psi / MPa	Pressure test, psi / MPa
4 1/2" (114)	5,23" (133)	3,81" (97)	4350 (30)	7250 (50)
5" (127)	5,74" (146)	4,05" (103)	4350 (30)	7250 (50)
5 1/2" (139,7)	6,25" (159)	4,60" (117)	4350 (30)	7250 (50)
5 3/4" (146)	6,53" (166)	4,88" (124)	4350 (30)	7250 (50)
6" (168,3)	7,4" (188)	5,66" (144)	4350 (30)	7250 (50)
7" (178)	7,71" (196)	6,06" (154)	3625 (25)	7250 (50)
9 " (244,5)	10,62" (270)	8,54" (217)	3625 (25)	5800 (40)
13 3/8" (339,7)	14,37" (365)	12,36" (314)	2900 (20)	4350 (30)

CASING CENTRALIZER



are designed to center casing strings during running and cementing in the well under operating conditions. The use of centralizers allows to obtain a uniform gap between the casing and the walls of the well, which eliminates the possibility of contact between them and provides complete isolation with cement mortar, without rupture, and therefore significantly extends the service life of pipes by reducing the rate of corrosion. The quality of cementing is significantly improved by performing the function of metal reinforcement in reinforced concrete formed behind the column after cement hardening.



CENTRALIZER-TURBOLIZER

are designed to equip casing strings. In order to ensure trouble-free descent of the pipe string into the well and centering it relative to the walls of the wellbore to obtain a cement stone of equal thickness, twisting around the casing and turbulizing the fluid flow in the annulus. The twisting of the flow significantly increases the efficiency of displacement and replacement of drilling mud with tampon in the zone of action of turbulators in the cavernous sections of the wellbore, as well as with the eccentric position of the string in the well. The scope of application of turbulators is universal - vertical, directional and horizontal, oil and gas wells.



The centerpieces are made to fit any size of casing

Junk sub PL-JP

are used during drilling operations to remove tool fragments: carbide attachments, bearings of drill bits, metal chips after using cutters, which cannot be removed using flushing mud. The Junk sub performs an important function of cleaning the well, increasing the service life of drill bits.



Well diameter, in /(mm)	Geometric size, in /(mm)	
	Max O.D. (in)/(mm)	Min. I.D. (in)/(mm)
5,5"-6" (139,7-152,4)	4,48"-5,51" (114-140)	1,49" (38)
6"-8" (152,4-203,2)	5,51"-7,75" (140-197)	1,88" (48)
8"-8,5" (203,2-215,9)	7,75" (197)	2,28" (58)
11"-13,5" (279,4-342,9)	8,62"-12,8" (219-327)	2,79" 71

* design dimensions can be changed and manufactured for individual technological conditions of the Customer's well

Well filter

are used in the development and operation of oil, gas and gas condensate wells. They prevent the ingress of significant rock particles during the opening of productive horizons and maintain effective filtration of produced fluids

Filter hermetic PL-HF

allows well flushing during casing run and at the bottomhole. Increase of well flow rate due to dissolution of shear caps as a result of their treatment with acid solutions.

Casing Size, in / (mm)	Length, not more than, in / (mm)	Quantity of hole per 1p.m., not more than, pieces.	Hole diameter after drilling, not more than, in / (mm)	MAX pressure test, psi / (MPa)
4" (101,6)	492,12 (12500)	70	0,7 (18)	1740 (12)
4 1/2 (114,3)	492,12 (12500)	70	0,7 (18)	1740 (12)
5" (127)	492,12 (12500)	70	0,7 (18)	1740 (12)
5 1/2 (139,7)	492,12 (12500)	70	0,7 (18)	1740 (12)
5 3/4 (146)	492,12 (12500)	70	0,7 (18)	1740 (12)
6 5/8 (168,3)	492,12 (12500)	70	0,7 (18)	1740 (12)
7" (178)	492,12 (12500)	70	0,7 (18)	1740 (12)



Filter slotted PL-SF

provides effective filtration of produced fluid. Prevents the ingress of significant rock particles during the operation of wells.

Casing Size, in / (mm)	Length, not more than, in / (mm)	Quantity of hole per 1p.m., not more than, pieces.	Size grooves in/(mm)
4" (101,6)	492,12 (12500)	15	0,11-0,23 (3-6)
4 1/2 (114,3)	492,12 (12500)	15	0,11-0,23 (3-6)
5" (127)	492,12 (12500)	15	0,11-0,23 (3-6)
5 1/2 (139,7)	492,12 (12500)	15	0,11-0,23 (3-6)
5 3/4 (146)	492,12 (12500)	15	0,11-0,23 (3-6)
6 5/8 (168,3)	492,12 (12500)	15	0,11-0,23 (3-6)
7" (178)	492,12 (12500)	15	0,11-0,23 (3-6)



DOWNLOAD
catalog

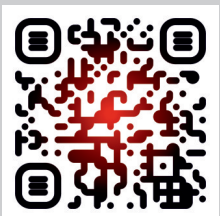

+38 050 242 74 77



www.pilot-dt.com
pilot@pilot-dt.com



36008, Ukraine, Poltava
Yevropeys'ka st.163

